

OPERATING INSTRUCTIONS AND SYSTEM DESCRIPTION OF THE SEC-10LX SINGLE ELECTRODE SYSTEMS

WITH APPENDICES:

- **SEC Cell Model**
- **Tuning Capacity Compensation in SEC Amplifier Systems**
- **SEC-EXT Headstage for Extracellular Recordings with SEC Systems**
- **Calibration of SEC Amplifiers with x10 Headstage**
- **Calibration of SEC Amplifiers with x0.1 Low Voltage Headstage**
- **Synchronization of Two or More SEC Amplifier Systems**
- **SEC Systems with VCcCC mode**
- **SEC Systems with DHC mode**
- **SEC Systems with Linear Mode**

VERSION 3.5
npi 2010

1. Safety Regulations

VERY IMPORTANT: Instruments and components supplied by npi electronic are NOT intended for clinical use or medical purposes (e.g. for diagnosis or treatment of humans) or for any other life-supporting system. npi electronic disclaims any warranties for such purpose. Equipment supplied by npi electronic must be operated only by selected, trained and adequately instructed personnel. For details please consult the GENERAL TERMS OF DELIVERY AND CONDITIONS OF BUSINESS of npi electronic, D-71732 Tamm, Germany.

- 1) **GENERAL:** This system is designed for use in scientific laboratories and must be operated by trained staff only. General safety regulations for operating electrical devices should be followed.
- 2) **AC MAINS CONNECTION:** While working with the npi systems, always adhere to the appropriate safety measures for handling electronic devices. Before using any device, please read manuals and instructions carefully.
The device is to be operated only at 115/230 Volt 60/50 Hz AC. Please check for appropriate line voltage before connecting any system to mains.
Always use a three-wire line cord and a mains power-plug with a protection contact connected to ground (protective earth).
Before opening the cabinet, unplug the instrument.
Unplug the instrument when replacing the fuse or changing line voltage. Replace fuse only with an appropriate specified type.
- 3) **STATIC ELECTRICITY:** Electronic equipment is sensitive to static discharges. Some devices such as sensor inputs are equipped with very sensitive FET amplifiers, which can be damaged by electrostatic charge and must therefore be handled with care. Electrostatic discharge can be avoided by touching a grounded metal surface when changing or adjusting sensors. **Always turn power off when adding or removing modules, connecting or disconnecting sensors, headstages or other components from the instrument or 19" cabinet.**
- 4) **TEMPERATURE DRIFT / WARM-UP TIME:** All analog electronic systems are sensitive to temperature changes. Therefore, all electronic instruments containing analog circuits should be used only in a warmed-up condition (i.e. after internal temperature has reached steady-state values). In most cases a warm-up period of 20-30 minutes is sufficient.
- 5) **HANDLING:** Please protect the device from moisture, heat, radiation and corrosive chemicals.

Warning

Safety precautions

To prevent fire or shock hazard, do not expose the unit to rain or moisture.

When working with the *SEC systems* manufactured by *npi electronic*, always adhere to the appropriate safety precautions for operation of electronic devices. Always use a 3-prong grounded outlet with a protected line plug. Disconnect the mains power plug before opening the unit or when replacing the fuse or changing the line voltage. Replace fuse with specified type only. Refer all servicing to *npi electronics*.

SEC 05H high-voltage headstage

The SEC 05H headstage has a ± 150 V output compliance and is equipped with a driven shield electrode connector. After turning on the unit, ensure that the interior contact and the electrode plug shield and the shield of the cable connected to it cannot be touched accidentally. It is also extremely important to turn the unit off before changing or adjusting the electrode.

Static electricity hazard

As all *npi* headstages are equipped with very sensitive FET amplifiers, they must be handled with care. FET amplifiers are susceptible to damage by static electricity. Therefore, the user should always touch a grounded metal surface before changing or adjusting the electrode. If not used the input of the headstage is should always be grounded (either using an appropriate connector or by wrapping aluminum foil around the headstage).

Caution:

Always turn the power off before connecting or disconnecting headstages from the 19" cabinet.

Table of Contents

Introduction

- 4 Welcome
 - 5 Why a Single Electrode Voltage Clamp?
 - 7 Principle of Operation
 - 8 Advantages of the npi System
-

Getting Started

- 9 General System Description
Modes of Operation
 - 10 Available Headstages
 - 11 Unpacking
 - 12 Setting Up and Connecting
 - 13 Tuning Procedures
Adjusting the Bridge Balance
 - 14 Capacity Compensation Adjustment
Tuning the CC Control
 - 15 Adjusting the Cap. Comp.
 - 16 Headstage Bias Current Adjustment
 - 17 Tuning Procedures in VC Mode
-

Sample Recordings

- 18 Recordings Using a Cell Model
 - 20 Whole-Cell Recording
 - 21 Intracellular Recording
-

Description of Components

- 22 Front Panel
 - 29 Rear Panel
-

- 30 Literature

Welcome!

Thank you for purchasing an SEC Single Electrode Amplifier.

Npi electronic's SEC Single Electrode Systems are based on the newest developments in the field of modern electronics and control theory. These versatile current/voltage clamp amplifiers permit extremely rapid switching between current injection and current-free recording of true intracellular potentials.

The use of modern high-voltage operational amplifiers and a new, improved method of capacity compensation makes it possible to inject very short current pulses through high resistance microelectrodes (up to 120 M Ω) and to record membrane potentials accurately within the same cycle.

The system has been designed primarily to overcome the limitations related with the use of high resistance electrodes in intracellular recordings, but it can also be used with suction electrodes like those employed in conventional whole-cell patch clamp experiments. These electrodes allow the user to investigate even small dissociated or cultured cells as well as cells in slice preparations in both the voltage mode and current clamp mode, while the intracellular medium is being controlled by a pipette solution.

Npi electronic's Single Electrode Systems are independent devices that incorporate four instruments in one:

- Very fast switching current clamp
- Fast and precise voltage clamp
- High precision bridge amplifier
- Electrode resistance measurement

The only external components required are a digital timing unit and an oscilloscope.

Why a Single Electrode Voltage Clamp?

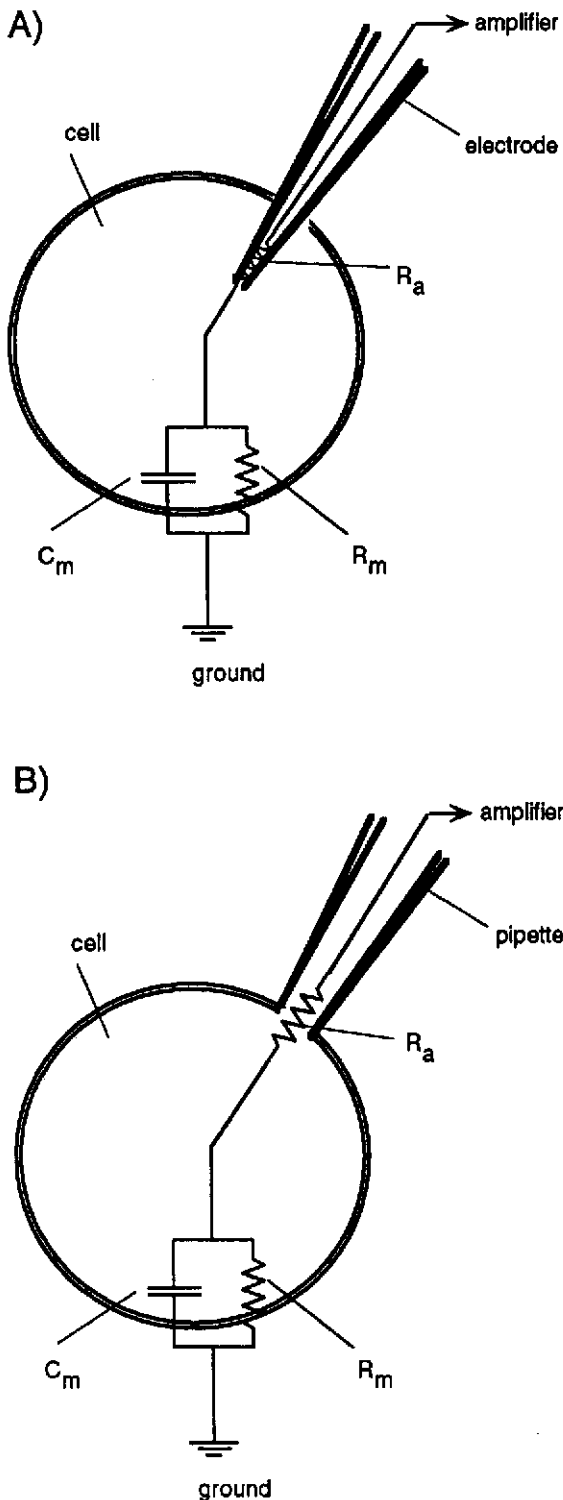

Fig.1: Model circuits for intracellular (A) and patch-clamp recording in the whole cell configuration (B).

Voltage clamp techniques permit the analysis of ionic currents flowing through biological membranes at preset membrane potentials. Under ideal conditions the recorded current is directly related to the conductance changes in the membrane and thus gives an accurate measure of the activity of ion channels and electrogenic pumps.

The membrane potential is generally kept at a preselected value (*command* or *holding potential*). Ionic currents are then activated by sudden changes in potential (e.g. voltage-gated ion channels), by transmitter release at synapses (e.g. electrical stimulation of fiber tracts in brain slices) or by external application of an appropriate agonist. Sudden command potential changes like those used to activate voltage-gated Na^+ , K^+ or Ca^{2+} currents are especially challenging, because the membrane will adopt the new potential value only after its capacitance (C_m) has been charged. Therefore, the initial transient current following the voltage step should be as large as possible to achieve rapid membrane charging. In conventional patch clamp amplifiers, this requires a minimal resistance between the amplifier and the cell interior - a simple consequence of Ohms law ($\Delta U = RI$): for a given voltage difference (ΔU), the current (I) is inversely proportional to the resistance (R). In this context, R is the *access* or *series resistance* (R_a) between the electrode and the cell interior. The time constant for charging a cell is $\tau = R_a * C_m$ (series resistance times membrane capacitance).

R_a is largely determined by certain electrode properties (e.g. pipette resistance) and the connection between the electrode and the cell. Typical R_a values obtained with suction electrodes are around 5 to 10 $\text{M}\Omega$, which would result in a time constant of 0.5 to 1 ms for a cell with a membrane capacitance of 100 pF. (Thus the membrane needs roughly a millisecond to follow the command voltage step.) Intracellular electrodes have much larger resistances (30 to 120 $\text{M}\Omega$).

Besides slowing the voltage response of the cell, R_a can also cause additional adverse effects, such as error in the potential measurement. R_a , together with membrane resistance (R_m), forms a voltage divider (Fig. 1). Current flowing from the amplifier to the grounded bath of a cell preparation will cause a voltage decrease at both R_a and R_m . If $R_a \ll R_m$, the majority of the voltage decrease will develop at R_m and thus reflect a true membrane potential. If, in an extreme case, $R_a = R_m$, the membrane potential will follow only half of the voltage command. To achieve a voltage error of less than 1% R_a must be more than a 100 times smaller than R_m . This condition is not always easy to achieve, especially if the recordings are made from small cells. If conventional intracellular electrodes are used, it is virtually impossible. If R_a is not negligible, precise determination of the pure membrane potential R_m is possible only when no current is flowing across R_a . This is the strategy employed in *npi electronic's SEC amplifier systems*.

The *SEC amplifiers* inject current and record the potential in an alternating mode, which is why the technique is called *discontinuous SEVC*. This ensures that no current passes through R_a during potential recording and completely eliminates access resistance artifacts.

After each injection of current, the potential gradient at the electrode tip decays faster than the potential added at the cell membrane during the same injection. The momentary membrane potential is measured after the potential difference across R_a has completely dropped. The difference between this value and the command potential determines the size of the next current injection. The discontinuous current and voltage signals are then smoothed and read at the CURRENT OUTPUT ③¹ and the POTENTIAL OUTPUT ④ connectors.

¹ Circled numbers refer to the parts on the front panel of the unit illustrated toward the end of the manual.

Principle of Operation

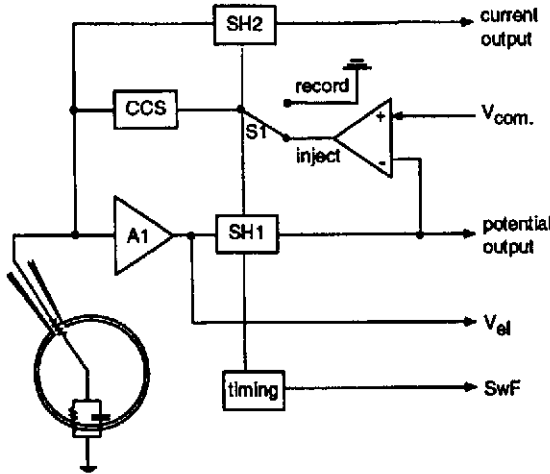

Fig. 2a: Model circuit of npf's SEC systems. See text for details.

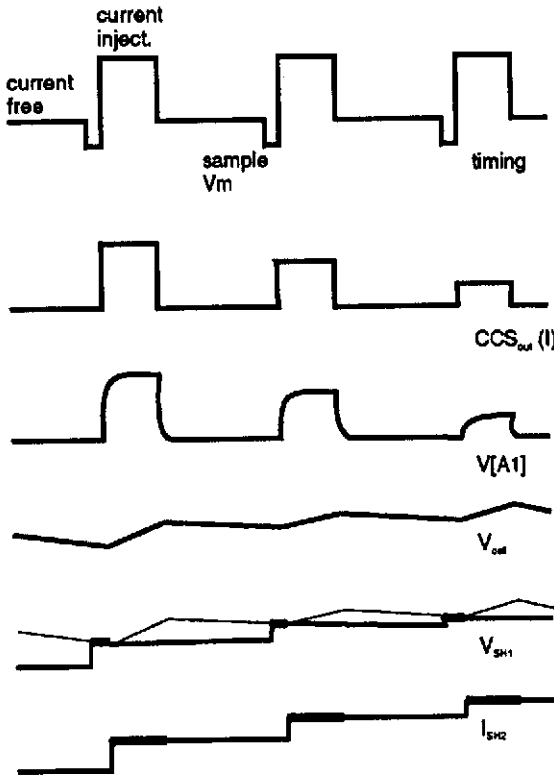

Fig. 2b: Principle of SEVC operation

Figure 2 illustrates the basic circuitry and operation of the SEC 05 discontinuous single electrode voltage clamp. A single microelectrode penetrates the cell or is connected to the cell interior in the whole cell configuration of the patch clamp technique. The recorded voltage is buffered by an x1 operational amplifier (A1). At this point, the potential ($V[A1]$) is the sum of the cell's membrane potential and the voltage gradient which develops when current injected at the access resistance. Due to our unique compensation circuitry, the voltage at the tip of the electrode decays extremely fast after each injection of current and therefore allows for a correct assessment of V_m after a few microseconds. At the end of the current-free interval, when the electrode potential has dropped to zero, the sample-and-hold circuit (SH1) samples V_m and holds the value for the remainder of the cycle. (Figs. 2 a and b; V_{SH1}). The differential amplifier (A2) compares the sampled potential with the command potential (V_{com}). The output of this amplifier becomes the input of a controlled current source (CCS) if the switch S1 is in the current-passing position. The gain of this current source increases as much as $100 \mu A/V$ due to a PI (proportional-integral) controller and improved electrode capacity compensation. In Fig. 2a S1 is shown in the current passing position, when a square pulse of current is applied to the electrode. When the current passes the electrode, a steep voltage gradient develops at the electrode resistance. V_{cell} is only slightly changed due to the slow charging of the cell capacitance. The amplitude of the injected current is sampled in the sample-and-hold amplifier SH2, multiplied by the fractional time of current injection within each duty cycle ($1/8$ to $1/2$) and read out as current output I_{SH2} . S1 then switches to the voltage-recording position (input to the CCS is 0). The potential at A1 decays rapidly due to the fast relaxation at the (compensated) electrode capacitance. Exact capacitance compensation is essential to yield an optimally flat voltage trace at the

end of the current-free interval when V_{cell} is measured. The cellular membrane potential, however, will relax much slower due to the large (uncompensated) membrane capacitance. The interval between two current injection pulses must be long enough to allow for complete ($\leq 1\%$) settling of the electrode potential, but short enough to minimize the loss of charges at the cell membrane level (minimal relaxation of V_{cell}). At the end of the current-free period a new V_m sample is taken and a new cycle begins. Thus, both current and potential output are based on discontinuous signals which are stored during each cycle in the sample-and-hold amplifiers SH1 and SH2. The signals will be optimally smooth at maximal switching frequencies.

Advantages of the Npi System

Npi electronic's SEC amplifiers are the only systems that use a PI controller to avoid artificial recordings known to occur in other single electrode clamp systems ("clamping of the electrode"). The PI controller design increases the clamp gain to as much as $100 \mu\text{A/V}$ in frequencies less than one-fourth the switching frequency. This results in a very sensitive control of the membrane potential with a steady-state error of less than 1% and a fast response of the clamp to command steps.

The use of discontinuous current and voltage clamp in combination with high switching frequencies in *npi's* SEC systems yields five major advantages:

1. The large recording bandwidth makes it possible to record even fast signals accurately.
2. High clamp gains (up to $100 \mu\text{A/V}$) can be used in the voltage clamp mode.
3. It is possible to voltage-clamp very small cells with relatively short membrane time constants.
4. Series resistance effects can be completely eliminated allowing for a correct membrane potential control even with high resistance electrodes.
5. The true membrane potential is recorded in the voltage clamp mode (whereas continuous feedback VC amplifiers only reflect the command potential).

Getting Started

General System Description

All SEC systems consist of a 19" rack-mountable unit with a built-in power supply and a headstage, which should be placed close to the recording site. The recording electrode is connected to the headstage either via a SUBCLIC connector and a short cable or via a BNC connector and a suction electrode holder.

All electrode connectors use a driven shield approach to minimize the capacitive effect of the connecting cable. Furthermore, all low-voltage headstages are equipped with a ground connector and a connector providing the driven shield signal. The SEC 05H high-voltage headstage is equipped with a ground connector only.

Modes of Operation

To cover all the needs of electrophysiological research, *npi electronic's SEC systems* have four modes of operation. Besides the discontinuous modes (CC = current clamp mode and VC = voltage clamp mode), all systems also have two linear modes of operation: the bridge mode (= BR, compensation of the electrode resistance by a linear bridge circuit) and an automatic electrode resistance test mode (= Rel). The VC, CC and BR modes are selected using a rotary switch ⑳, which has a fourth position for external control of the system (EXT). The Rel mode is activated by a toggle switch.

Some functions of the SEC 05 systems can be controlled by digital signals (EXT position of the MODE switch ⑳). In the standard unit this setting allows the operator to switch from CC to VC by means of an external TTL pulse applied to the MODE SELECT BNC connector ㉓.

Additional functions controlled by an external digital computer can be accessed using the *npi interface card* (optional).

Available Headstages

The *SEC 05 system* has four different headstages to choose from:

1. The **low-voltage headstage** is the standard version for intracellular recordings using high resistance microelectrodes or low resistance suction electrodes for whole-cell patch-clamp recordings. The low-voltage headstage has the capability to inject a maximum current of approximately ± 120 nA into a resistance of $100\text{ M}\Omega$. Considering the duty cycle (1/2, 1/4, 1/8) in the discontinuous modes of operation the maximum effective range of current is 60 nA, 30 nA and 15 nA into $100\text{ M}\Omega$.
2. The **high-voltage headstage** is designed for recording larger currents up to the μA range (e.g. from *Xenopus* oocytes). This headstage has the capability to inject $1.2\text{ }\mu\text{A}$ (600 nA, 300 nA or 150 nA in the discontinuous modes) into a resistance of $100\text{ M}\Omega$ or, alternatively, $12\text{ }\mu\text{A}$ (6 μA , 3 μA , 1.5 μA in the discontinuous modes) into $10\text{ M}\Omega$. The current range of the high-voltage headstage is 10 times higher than that of the standard headstage. Therefore, all current related signals have to be multiplied by ten.
3. The **x10 low-voltage headstage** can record currents larger than those that can be measured using the standard version. This headstage is normally operated using suction (low resistance electrodes), and it has an output current range of $1\text{ }\mu\text{A}/10\text{ M}\Omega$. The calibration is the same as for the high-voltage headstage.
4. The **x0.1 low-voltage headstage** is used for low-noise recording of small currents ($\geq 10\text{ pA}$) via whole cell patch-clamp technique or for making recordings from very small cells. This headstage has an output current range of 15 nA into $100\text{ M}\Omega$, and the noise and bias current are 10 times lower than that of the standard headstage. All current related signals must be divided by 10.

Setup - Step by Step

Unpacking

The following items should be included with your amplifier:

- Headstage
- Headstage cable
- Electrode cable
- Bath ground
- Power cord
- User's manual

If any of these items are missing please contact *npi electronics* immediately!

After unpacking the SEC amplifier and accessories, check each piece for any signs of shipping damage. Please contact the delivering carrier and *npi electronics* immediately if there is any damage. All *npi* shipments are insured against shipping damages. It is advisable to keep the shipping box in the event that the unit must be returned for servicing.

Setting Up and Connecting

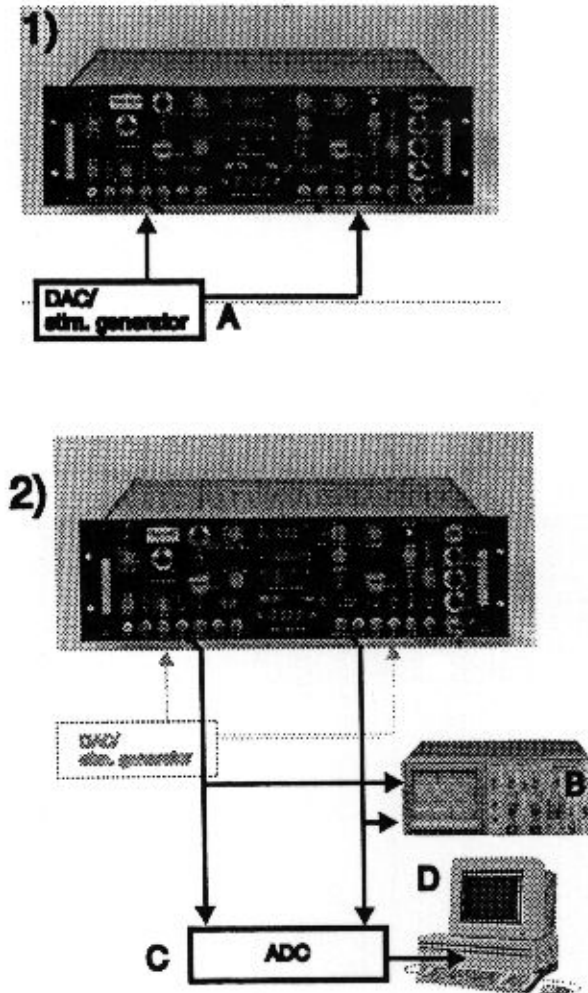

Fig. 3: Connecting the SEC 05

1. Connect a digital or analog timing and pulse unit (A) to the respective inputs (**VOLTAGE COMMAND INPUT** 32 and **CURRENT STIMULUS INPUT** 4, 41).
2. Connect a storage oscilloscope (B) to the **POTENTIAL OUTPUT** 34 and to the **CURRENT OUTPUT** 37 (triggered with the trigger signal from the timing unit). You might want to connect an analog-to-digital converter and a computer to the same connectors (by using a T-connector).
3. Connect a normal oscilloscope (E) to the **ELECTRODE POTENTIAL (Vel)** connector on the rear panel. This oscilloscope is triggered by the **SWITCHING FREQUENCY** signal (rear panel).
4. Connect the electrode cable and the bath ground to the respective connectors on the headstage.² Use a cell model for test measurement. Connect the headstage to the **HEADSTAGE INPUT** 3.
5. Turn the **POWER** switch 1 on and let the amplifier warm up for at least 30 minutes. Reset the **OSCILLATION SHUT-OFF** 9 (LED = green) and select the **BR** mode 20. All controls (**DISPLAY** 5, 6) should be on low values, and **OFFSET** 22 should be in the range of ± 5 mV.
 - Adjust **HEADSTAGE BIAS CURRENT** 18 to zero and nullify the potential offset using the **OFFSET** 22 control (page 16).
 - In order to measure the resistance in the R mode, place the electrode in the bath (not in a cell).
8. Apply a current step (BR mode or CC mode) to the **CURR. STIMULUS INPUT** 21 and adjust either the **BRIDGE BALANCE** 13 (BR mode, see page 13) or the **CAP. COMP.** 23 (CC mode, see page 15).

Now the system is ready for use.

² Ground yourself properly before touching the headstage!

Tuning Procedures

Adjusting the Bridge Balance

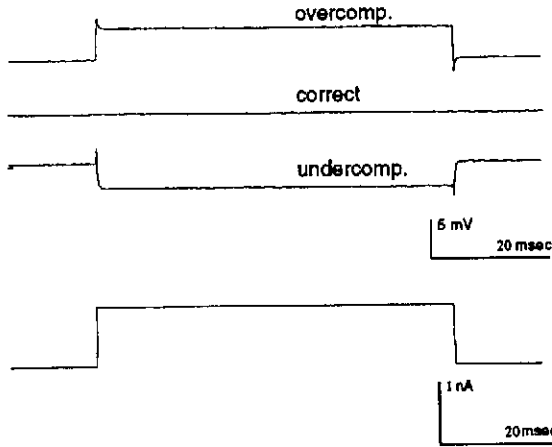

Fig. 4a: Adjustment of the bridge balance. Lower lane: current stimulus, upper lanes: potential output.

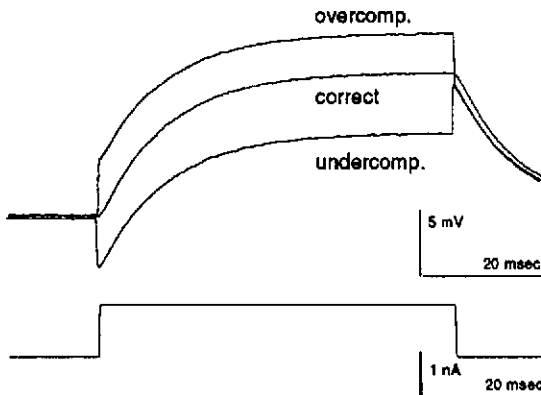

Fig. 4b: Adjustment of the bridge balance after establishing the whole-cell configuration. Lower lane: current stimulus, upper lanes: potential output.

Patch Clamp Electrode Selection

Caution

It is of major importance that the SEC systems be warmed-up prior to operation. Especially when using the high-voltage headstage or before performing the headstage bias current tuning procedure, the unit should be warmed-up for at least 30 minutes.

The tuning of the bridge balance is performed with the help of the **POTENTIAL OUTPUT** ② signal, which is displayed on a storage oscilloscope. The following adjustments are performed with the electrode immersed in the bath as deep as necessary during the experiment.

To adjust the bridge balance, switch to the **BR mode** ⑩ and apply current to the **CURR. STIMULUS INPUT** ⑪. Turn **BRIDGE BALANCE** ⑬ until the potential trace on the oscilloscope connected to **POTENTIAL OUTPUT** ② is flat (Fig. 4a). The potentiometer reading shows the electrode resistance.

Sometimes the bridge balance has to be readjusted after establishing an intracellular recording or the whole-cell configuration (Fig. 4b).

Before performing a patch clamp experiment the electrodes should be tested in the **BR mode** by applying positive and negative current pulses. Electrodes with significant rectification cannot be used for voltage clamping. The current carrying capability of the electrode can be estimated by increasing the current amplitude. The current generated in the **VC mode** should not exceed this amount and must be limited using the **VC OUTPUT LIMITER** ⑭.

Capacity Compensation Adjustment

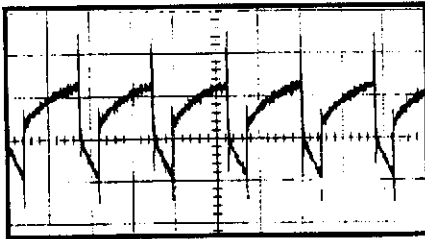

undercompensated

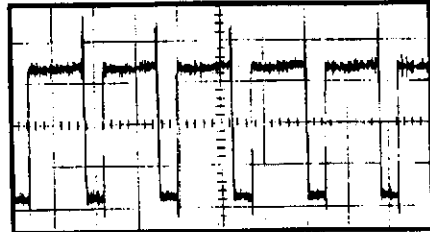

correct

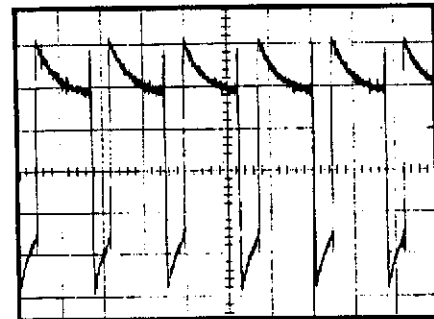

overcompensated

Fig. 5: Adjustment of capacity compensation

Using the CC Control (Headstage)

Capacity compensation adjustment is performed using the **ELECTRODE POTENTIAL** signal (connector at the rear panel). This signal is displayed on a regular (i.e. non-storage) oscilloscope which is triggered by the **SWITCHING FREQUENCY** signal (connector at the rear panel). Correct tuning of the capacity compensation is essential for proper switched mode operation (CC and VC).

The SEC 05 recording system has two controls for capacity compensation: one located on the front panel **CAP. COMP.** (ten-step control) and one located at the headstage (**CC**). The **CC** control at the headstage adapts the bandwidth to the time constant of the electrode. This control has to be readjusted only if the set-up arrangement or the type of electrode has been changed. The **CAP. COMP.** ② control on the front panel is the conventional feedback compensation. This control is used for **CC** tuning during an experiment.

To adjust the capacity compensation on the headstage, immerse the electrode in the bath as deep as necessary during the experiment. Then apply positive and negative currents with the **HOLDING CURRENT** control ③ at the lowest switching frequency ① in the **CC** mode. A clear signal on the oscilloscope should be visible (Fig. 5). The **CAP. COMP.** control ② is on a low position (1 - 3 on the dial). Now the **CC** control (headstage) is turned on (clockwise) until the signals on the oscilloscope connected to the **ELECTRODE POTENTIAL OUTPUT** (on the rear of the instrument) are as square as possible (Fig. 5 middle).

By increasing the **SWITCHING FREQUENCY** ①, no considerable change in the amplitude and shape of these pulses should occur.

Adjusting the CAP. COMP.

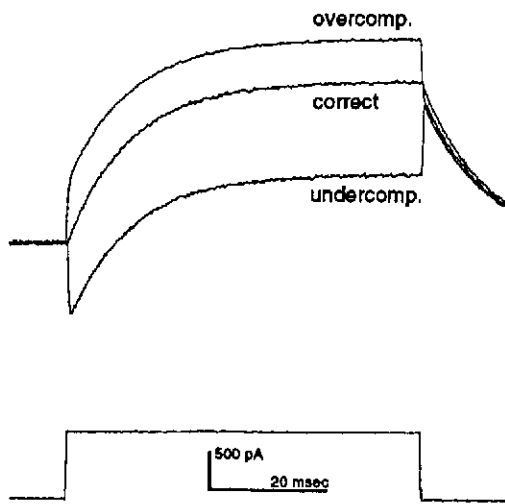

Fig. 6: Adjustment of the capacity compensation. Lower lane: current stimulus; upper lanes: potential output in whole cell configuration.

The cap. comp. setting must be adjusted before and during an experiment.

After adjusting the CC setting (headstage see p. 14), switch off the **HOLDING CURRENT** 21 (bring toggle switch in middle position) and apply square pulses (positive and negative) of a few nA (intracellular recordings) or 10 to 100 pA (patch clamp recordings) and 5 to 10 msec duration to one of the **CURRENT STIMULUS INPUT BNCs** 40 or 41.

The signals from the **POTENTIAL OUTPUT** 34 and **CURRENT OUTPUT** 37 BNCs are monitored on a storage scope.

Set the **SWITCHING FREQUENCY** 17 and **DUTY CYCLE** 16 to the desired values. The switching frequency should be at least 12 to 15 kHz.

Now turn the **CAP. COMP.** 21 control clockwise until there is no artifact on the **POTENTIAL OUTPUT BNC** 34 (Fig. 6).

The shape of the injection pulses on the **ELECTRODE POTENTIAL OUTPUT** (rear panel) must be still square (Fig 5). If not, the CC control must be readjusted or the switching frequency is too high.

Hint:

If all settings are correct, no difference in potential output (e.g. no offset) should occur when switching from BK to CC mode!

Headstage Bias Current Adjustment

Caution:

A warm-up period of at least 30 minutes is required for this tuning procedure!

The zero current of the headstage is tuned using the HEADSTAGE BIAS CURRENT control 18. This tuning procedure must be performed before starting a recording session.

A high-value resistor or a cell model is required for tuning. The amplifier must be in the BR mode 20. The procedure cannot be performed with an electrode, since there are always unknown potentials involved (tip potential, junction potentials).

1. To trigger the oscillation shut-off unit 8 (LED = red) the amplifier is caused to oscillate by over-compensating the CAP. COMP. 21. The DISABLED/RESET switch 8 must be in middle position to avoid incoming signals from the CURRENT STIMULUS UNITS.
2. The electrode output on the headstage is connected to ground via a 10 - 100 k Ω resistor and the offset on the potential DISPLAY 5 is tuned to 0 mV with the OFFSET control 22.

After tuning the offset connect a large resistor (about 100 M Ω) as if an electrode were attached.

1. The potential now appearing on the potential DISPLAY 5 is related to the bias current of the headstage according to Ohm's Law. Cancel out this voltage using the HEADSTAGE BIAS CURRENT potentiometer 18.
2. Now both DISPLAYS 5 and 6 should read 000. Potentiometers 18 and 22 are usually close to 5.

An offset of ± 001 to ± 002 on the displays can occur due to the limited resolution of the displays, unbalanced offsets and thermal drifts. This small deviation is generally negligible but if very small current in the pA range is recorded, it can be trimmed internally. Ask *npi technical support* for details.

Tuning Procedures in VC mode

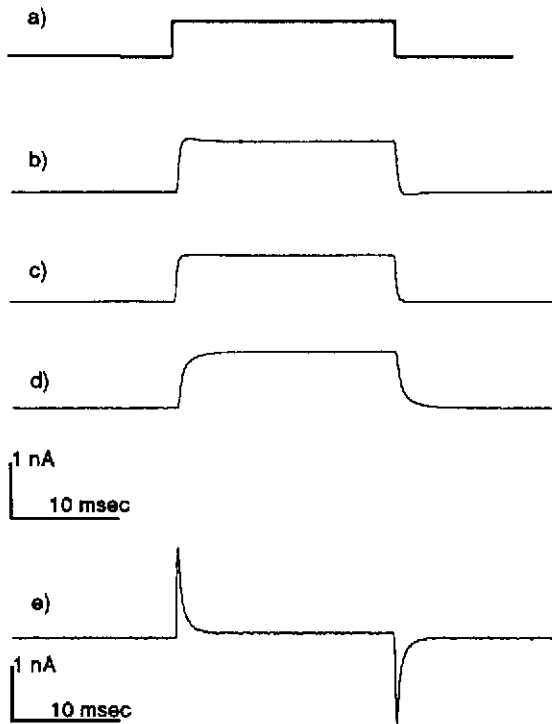

Fig. 7: Tuning of the capacity compensation in VC mode. a) voltage command, potential output b) overcompensated, c) correct, d) undercompensated; e) current stimulus.

The settings in the VC mode should be optimized for each cell to yield the best possible voltage control and recording bandwidth. With the electrode in the bath, it is best to start in the CC mode 20. The POTENTIAL OUTPUT 34 and CURRENT OUTPUT 37 signals are monitored on a storage scope. The GAIN CONTROL 15 should be set at around 0.5, the INTEGRATOR TIME CONSTANT (τ) 3 has to be turned off (toggle switch).

1. Turn the HOLDING POTENTIAL 19 until VC ERROR 2 is around 0. Now the preadjusted VC command voltage corresponds exactly to the actual membrane potential in CC configuration.
2. Most cells survive best at membrane potentials of -50 to -80 mV. If necessary preadjust such a potential in the CC mode injecting DC current at 21.
3. Set VC MODE using 20 and apply voltage steps of ca. 10mV to the VC COMMAND INPUT BNC 32 (toggle switch ON). If oscillations occur lower GAIN 14 or readjust CAP. COMP. In CC mode (see page 15).
4. Adjust GAIN 14 and INTEGRATOR TIME CONSTANT 3 until the voltage signal on the oscilloscope becomes as square as possible (Fig. 7c).
5. An overshoot (Fig. 7b) can be adjusted using the RISE TIME compensation 24.

Sample Recordings

Recordings Using a Cell Model

The following recordings were made using the *npi SEC cell model*.

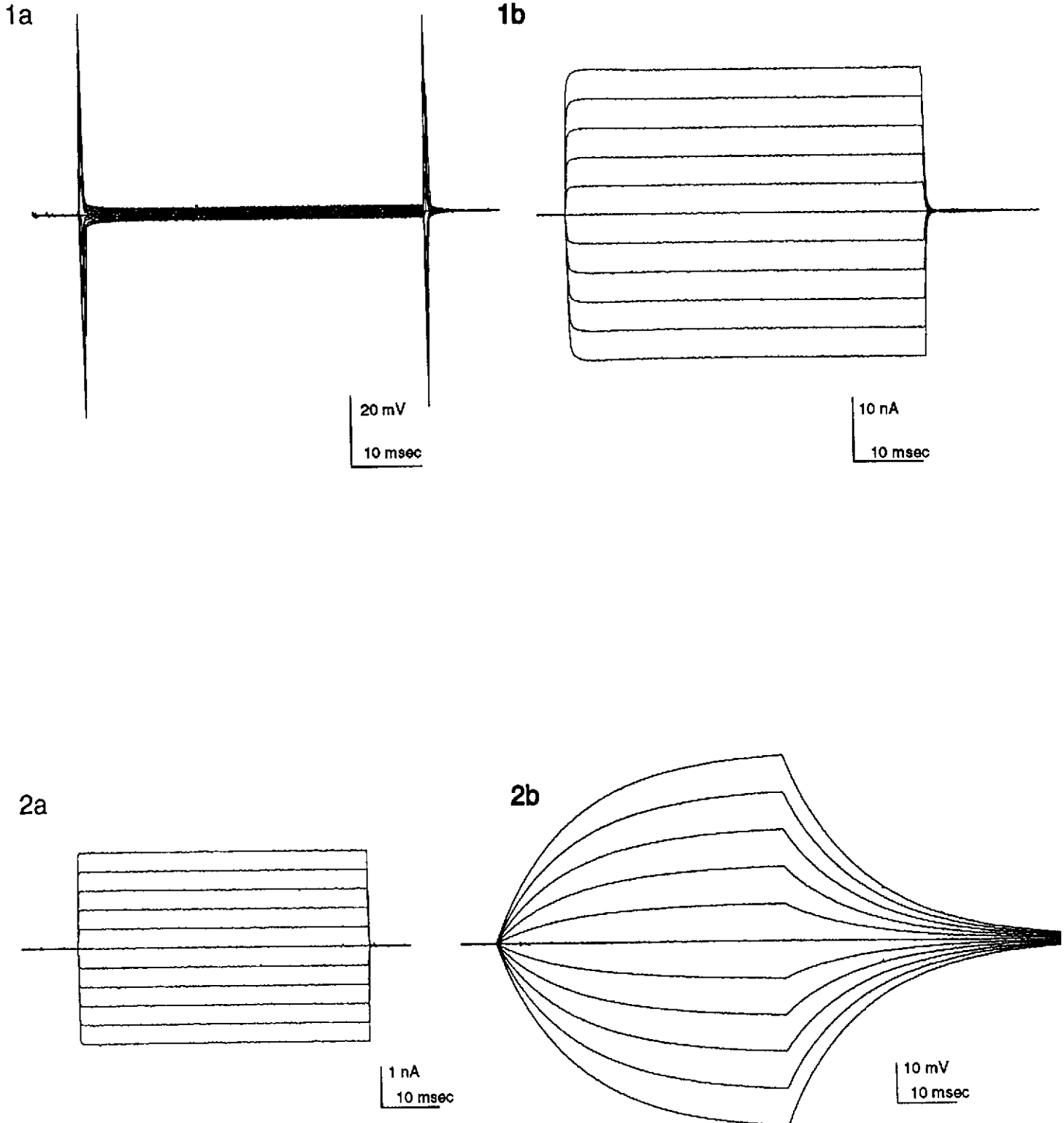
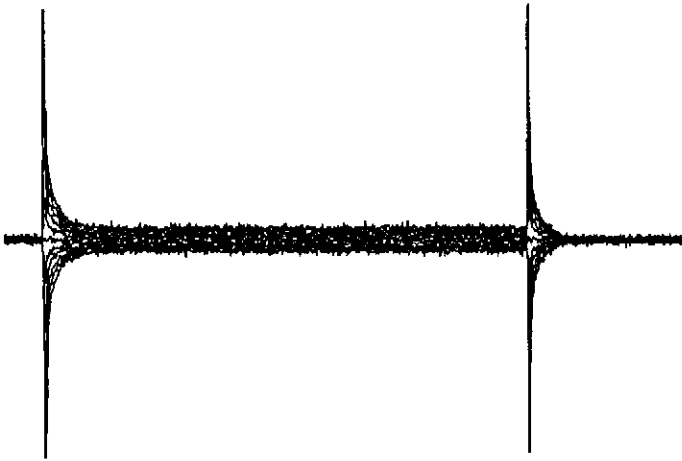

Fig. 8: Behavior of the test cell model in the VC (1b) and CC modes (2b) for a series of voltage (1a) or current steps (2a). Simulation of a patch clamp experiment in whole cell configuration.

1a



10 mV
10 msec

1b

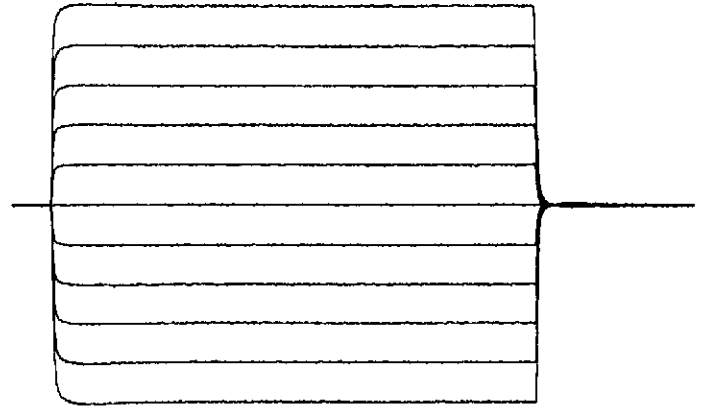

10 nA
10 msec

2a

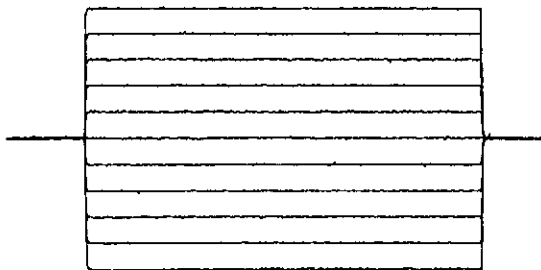

1 nA
10 msec

2b

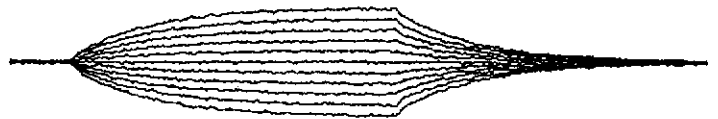

25 mV
10 msec

Fig. 9: Behavior of the test cell model in VC (1b) and CC modes (2b) for a series of voltage (1a) or current steps (2a). Simulation of an intracellular recording.

Whole-Cell Recording - Step by Step

- Start with amplifier in the CC mode

- Apply positive pressure to the patch pipette.
- Immerse the patch pipette into the bath to the same depth as during the experiment.
- Tune potential offset ⑳ (page 12).
- Apply constant current ㉑.
- Check headstage capacity compensation and correct if necessary (page 14).
- Turn holding current off ㉒.

- Switch to BR mode ㉓

a

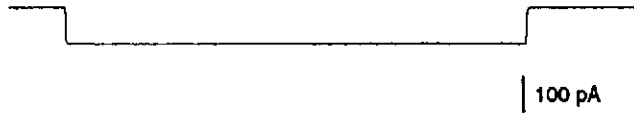

b

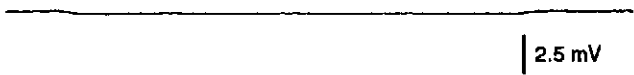

- Apply test pulse to ㉔ (e.g. 100 pA) (Fig. 10a).

- Tune bridge balance ㉕ (page 13).

- Voltage signal should be flat (Fig. 10b).

- Determine electrode resistance ㉖ or ㉗ (page 13).

- Decrease test pulse to 10 pA.

- Approach cell until voltage trace changes (Fig. 10c).

- Release pressure from pipette, if seal does not form, apply suction.

- Watch voltage signal until gigaseal is established (Fig. 10d).

- Apply stronger suction to pipette until whole cell configuration is established (Fig. 10d).

- Read membrane potential. If necessary apply holding current as needed to obtain the required value ㉘.

- Correct bridge balance ㉕ (page 13)

- Switch to CC mode. If a change in voltage occurs, correct CAP. COMP. using ㉙ (page 15). (Watch control oscilloscope).

Start recording in CC or VC mode.

c



d

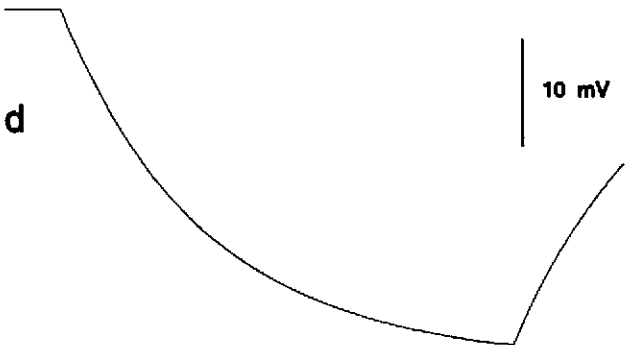

e

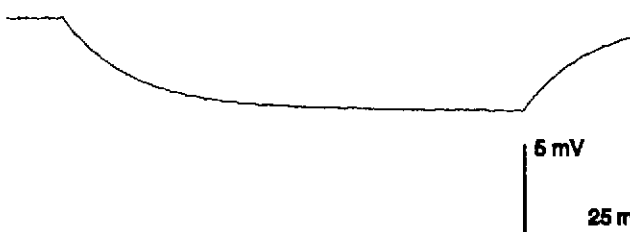

Intracellular Recording - Step by Step

- Start with amplifier in the CC mode

- Switch to BR mode 20

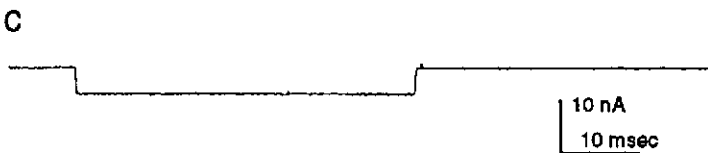
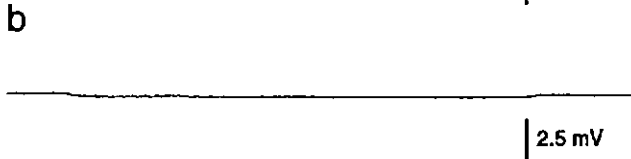
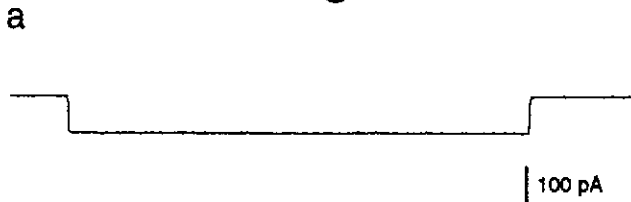

- Immerse the microelectrode into the bath to the same depth as during the experiment.
- Tune potential offset 22 (page 12).
- Apply constant current.
- Check the headstage capacity compensation and correct if necessary (page 14).
- Turn the holding current off 21.
- Apply test pulse to 41 (e.g. 100 pA - 1 nA) (Fig. 11a).
- Tune bridge balance 13 (page 13).
- Voltage signal should be flat (Fig. 11b).
- Read electrode resistance 13 (page 13).
- Approach the cell. The electrode is close to the cell, if electrode resistance increases (bridge balance appears undercompensated), if extracellular APs are visible, or if the acoustic monitor signal changes.
- Penetrate cell via buzzing 10 - 12 or capacitance overcompensation 27, 21, 12.
- After penetration the V response (Fig. 11d) to the test pulse should reflect the time constant and the cell membrane resistance.
- Read membrane potential 21 and apply holding current to get the desired value, if necessary.
- Correct bridge balance 13 (page 13).
- If change in voltage occurs, correct CAP. COMP. using 20 (page 15). (Watch control oscilloscope).
- Start recording in the CC or VC mode.

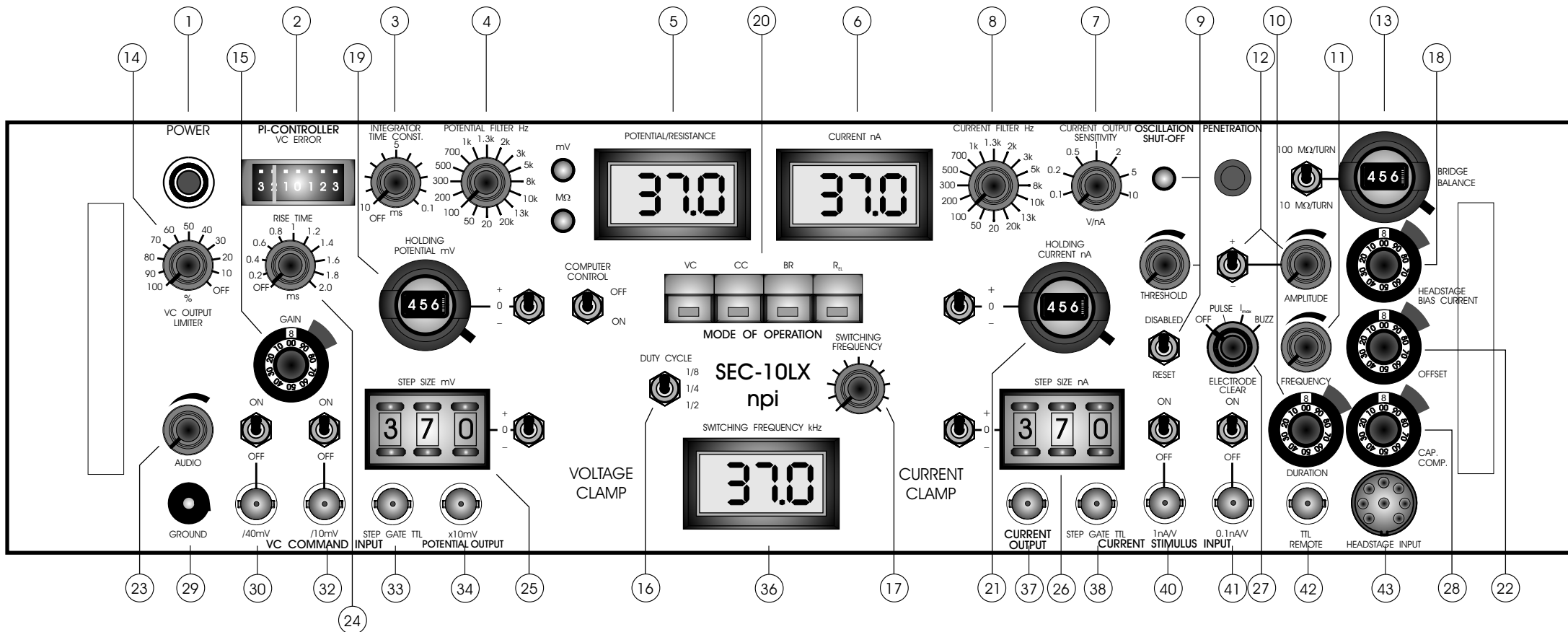

FRONT PANEL VIEW OF THE SEC 10LX AMPLIFIER SYSTEM

CONTROLS AND CONNECTORS

FRONT PANEL ELEMENTS

1 POWER

POWER

This switch turns on the power supply. The line fuse, line voltage selector and power cable connector are located on the rear panel.

2 VC ERROR

VC ERROR

This analog display shows the error in the VC (voltage clamp) mode (command minus recorded potential). The desired range of operation is around zero.

3 INTEGRATOR TIME CONSTANT

INTEGRATOR TIME CONSTANT

In the most left position the integrator is turned off i.e. the VC controller has only proportional characteristic. By turning the knob clockwise the integrator is set on i.e. the VC controller has a PI characteristic (proportional and integral), which reduces the error considerably (theoretically to zero). The time constant of the integrator is set with a ten-turn potentiometer **3** (clockwise: time constant is decreased, effect of integrator is increased). When using the integrator, step commands applied to the input can cause overshoots, which can be reduced with the **RISE TIME** control **24**.

4 POTENTIAL FILTER

POTENTIAL FILTER

Low pass Bessel filter for the POTENTIAL OUTPUT (see also **CURRENT FILTER 8**). The setting of the filter is monitored at **FREQUENCY MONITOR POTENTIAL** at the rear panel.

5, 6 DISPLAYS

DISPLAYS

5 POTENTIAL/RESISTANCE: display for the recorded potential in mV (B; C; V modes) or the electrode resistance in M Ω (R mode).

6 CURRENT nA: display for the membrane current in nA.

7 CURRENT OUTPUT SENSITIVITY

CURRENT OUTPUT SENSITIVITY

This switch sets the sensitivity of the current output (0.1-10 V/nA, seven position rotary switch). The setting of **OUTPUT SENSITIVITY** is monitored at **CURRENT SENSITIVITY MONITOR** at the rear panel.

8 CURRENT FILTER

CURRENT FILTER

(20Hz – 20 kHz, 16 position rotary switch)

- 4-pole tunable Bessel filter (24dB/oct) with 16 corner frequencies, selected by a rotary switch.
- The following 16 frequencies can be set: 20, 50, 100, 200, 300, 500, 700, 1k, 1.3k, 2k, 3k, 5k, 8k, 10k, 13k, 20k (Hz)

The setting of the filter is monitored at **FREQUENCY MONITOR CURRENT** at the rear panel.

9 OSCILLATION SHUT-OFF

OSCILLATION SHUT-OFF

Disconnects current injection and capacity compensation if parasitic oscillations occur.

- A **red/green LED** shows the state of the system (red = shut-off triggered).
- **THRESHOLD**: Sets the threshold for shut-off activation.
- **DISABLED/RESET** switch: resets or disables oscillation shut-off unit.

10 – 12 PENETRATION

CELL PENETRATION UNIT

This unit is used to clean the tip of the electrode and to facilitate the penetration of the cell membrane.

- The unit can be operated by a remote switch connected to the **REMOTE BNC 42** (active LOW).
- The duration can be set by the **DURATION** control **10**.
- It can be turned off by the mode select (**OFF/PULSE/I_{max}/BUZZ**) rotary switch **27**.
- **PULSE** mode: application of DC pulses. In the B (bridge mode) or C (switched current clamp mode) square pulses are applied to the electrode to clean the tip of the electrode or to facilitate cell penetration.
- The **PULSE** parameters are set by two controls and a switch: **AMPLITUDE** control **12**, **+/- polarity switch 12** and **FREQUENCY** control **11**.

- **I_{max}**: In this mode DC currents are applied to the electrode. The amplitude and polarity are also set by the respective controls (**AMPLITUDE**, +/- **polarity switch**)
- **BUZZ (= CAPACITY COMPENSATION mode)**: overcompensation of the capacity compensation, effective in all four modes of operation (R, B, C, V modes).

CAUTION: Once an appropriate cell is found, always turn off the PENETRATION UNIT (OFF position of switch 27)

13 BRIDGE BALANCE

BRIDGE BALANCE (MΩ)

In the B (= bridge) mode the electrode resistance is compensated with this control (ten turn potentiometer, clockwise); calibrated in MΩ.

100 MΩ / 10 MΩ switch: With this switch the range of the BRIDGE BALANCE control is set (10 MΩ / turn, i.e. 100 = 10 MΩ or 100 MΩ / turn, i.e. 100 = 100 MΩ)

14 VC OUTPUT LIMITER

VC OUTPUT LIMITER (Current Limit)

Under certain experimental conditions it is necessary to limit the current in the voltage clamp mode (e.g. in order to prevent blocking of the electrode or to protect the preparation). This is possible with an electronic limiter that sets the current range between 0 and 100%.

15 VC GAIN

VC GAIN

This control sets the gain of the VC controller, (range: 100nA/V – 10μA/V). The gain must be as high as possible.

16 DUTY CYCLE

DUTY CYCLE (1/8; 1/4; 1/2)

In discontinuous modes (V and C modes) this switch sets the ratio between current injection and potential recording mode (12.5%; 25% or 50% of each switching period).

17 SWITCHING FREQUENCY

SWITCHING FREQUENCY

In switched modes (V and C modes) the switching frequency for the discontinuous current injection is set with this control (ca. 1kHz - 50kHz). The selected frequency is shown on the display **36**.

18 HEADSTAGE BIAS CURRENT

HEADSTAGE BIAS CURRENT

With this 10 turn control the output current of the headstage can be tuned to zero (see following chapters).

19 VOLTAGE COMMAND INPUT

VOLTAGE COMMAND INPUT

(see also **CURRENT STIMULUS INPUT 21**). The command signal for the voltage clamp mode (V mode) is a sum of following input signals:

- **19 HOLDING POTENTIAL** (mV), with a +/0/- switch for selecting the polarity
- **32** analog input BNC (:10mV),
- **30** analog input BNC (:40mV),
- **33 GATE** (TTL) / **25 STEP SIZE** (mV) analogue to the current **GATE INPUT 38 / STEP SIZE** (nA) **26**

20 MODE OF OPERATION

MODE OF OPERATION

Push-button selector of the four operating modes, the selected mode of operation is indicated by a green LED at the respective push-button:

- R: ELECTRODE RESISTANCE TEST MODE (see **POTENTIAL** monitor)
- B: BRIDGE MODE (see **BRIDGE BALANCE** control **13**)
- C: CURRENT CLAMP MODE using discontinuous current injection.
- V: VOLTAGE CLAMP MODE using discontinuous feedback.

The mode of operation can be selected also by TTL signals connected to the respective BNC connectors at the rear panel.

21 CURRENT STIMULUS INPUT

CURRENT STIMULUS INPUT

The current injected through the electrode in the current clamp modes (B and C modes) is the sum of the following input signals:

- **21 HOLDING CURRENT** (nA): With this control a constant current can be generated, (ten turn potentiometer, clockwise), calibrated in nA. The polarity is selected with a +/0- toggle switch near the control.

- **40** Analog input (BNC connector), 1 nA/V
- **41** Analog input (BNC connector), 0.1 nA/V
All analog inputs have an ON/OFF switch.
- **38 STEP GATE (TTL) / 26 STEP SIZE (nA)**: With this input a current step set in nA with a digital potentiometer can be generated with a positive digital pulse (3-15V). The polarity is selected with a +/- toggle switch.

22 OFFSET

OFFSET

Control to zero the output of the electrode preamplifier (ten turn potentiometer, **5 = 0 mV**); up to +/-400 mV offset can be compensated.

23 AUDIO

AUDIO MONITOR

Output volume of audio monitor (voltage to frequency conversion of the recorded potential.)

24 RISE TIME

RISE TIME

Sometimes it is necessary to limit the rise time of a voltage clamp pulse especially in connection with PI-controllers to avoid overshooting of the potential. See also **3**.

25 STEP SIZE (mV)

STEP SIZE

Control for the amplitude of the voltage command step elicited by using the **STEP GATE TTL 33**. Polarity is selected by a +/- switch near the control. See also **19**.

26 STEP SIZE (nA)

STEP SIZE (nA)

With this digital potentiometer control the amplitude of a current step (set in nA) generated by using the **STEP GATE TTL 38** input. The polarity is selected with a +/- toggle switch near the control. See also **21**.

27 OFF/PULSE/I_{max}/BUZZ

MODE SWITCH

for the PENETRATION unit. See also 10.

28 CAP.COMP

CAPACITY COMPENSATION

Fine adjustment for the compensation of input capacitance (ten turn potentiometer, clockwise), up to 20 pF can be compensated. (Coarse compensation control on headstage (CC) and tuning procedure, see CAPACITY COMPENSATION chapter).

29 GROUND

GROUND plug

This connector is linked to the internal system ground, which has no connection to the 19" cabinet and the mains ground to avoid ground loops. Ground connectors are also on the rear

panel (see REAR PANEL ELEMENTS, GND/EARTH connectors).

30-33 VC COMMAND INPUT

VC COMMAND INPUT

- **30 :40 mV** input BNC connector. See **19**.
- **32 :10 mV** input BNC connector. See **19**.
- **33 STEP GATE TTL input BNC connector**. See **19**.

34 POTENTIAL OUTPUT (x10mV)

POTENTIAL OUTPUT

BNC connector monitoring the recorded potential with a gain of ten.

36 SWITCHING FREQUENCY kHz

SWITCHING FREQUENCY (kHz)

The selected switching frequency (see **17**) is displayed with a 3 digit display. In the linear modes (B and R modes) it must show zero.

37 CURRENT OUTPUT

CURRENT OUTPUT

BNC connector on the front panel, monitoring the effective (average) current passed through the electrode.

38 – 41 CURRENT STIMULUS INPUT

CURRENT STIMULUS INPUT

- **38 STEP GATE TTL** input BNC connector. See **21**.
- **40 1 nA/Volt** input BNC. See **21**.
- **41 0.1 nA/V** input BNC. See **21**.

42 REMOTE

REMOTE

BNC connector for activating the **PENETRATION UNIT** remotely. See also **10**.

43 HEADSTAGE INPUT

HEADSTAGE INPUT connector

The headstages are connected via a flexible cable and a 12-pole connector to the mainframe.

CAUTION: Please always adhere the appropriate safety regulations (see **SAFETY REGULATION** chapter). When connecting or disconnecting the headstages from the 19" cabinet connector please turn power off!

REAR PANEL ELEMENTS

- **SWITCHING OUTPUTS**

SWITCHING OUTPUTS (see Fig. 3)

These outputs provide signals for tuning of the switched operation modes (V and C modes). In the V and C modes these signals are necessary for tuning the capacity compensation (see following chapter).

- **SW FREQUENCY MONITOR**

BNC-connector monitoring the selected switching frequency (+5V pulses), used to trigger the oscilloscope which displays the switching pulses.

- **ELECTRODE POTENTIAL (V_{EL}):**

BNC connector monitoring the electrode potential, i.e. the response of the electrode to the discontinuous current injection

- **MODE OF OPERATION**

MODE OF OPERATION

(TTL) (BR, CC, VC, REL)

These inputs can be used to select the mode of operation by means of TTL pulses from a digital computer or timing unit (see also **20**).

- **CURR.SENSITIVITY BNC**

CURRENT SENSITIVITY

MONITOR: This BNC connector provides eight output voltages (1-7V, 1V per switch position) corresponding to the seven positions of the **CURRENT OUTPUT SENSITIVITY** switch. See also **7**.

- **FREQUENCY MONITOR
CURRENT**

FREQUENCY MONITOR BNC

The position of the **CURRENT FILTER switch 8** is monitored at the **FREQUENCY MONITOR BNC** (-8...+7 Volt, 1 Volt / switch position).

POTENTIAL

The position of the **POTENTIAL FILTER switch 4** is monitored at the **FREQUENCY MONITOR BNC** (-8...+7 Volt, 1 Volt / switch position).

- **GROUND / PROTECTIVE EARTH**

GROUND / PROTECTIVE EARTH

Connectors; see also **29**.

In order to avoid ground loops, the internal zero (ground) signal of the instrument is not connected to the mains ground and the cabinet. The cabinet and mains ground are connected to the green/yellow connector, the internal ground is connected to the yellow connector.

- **POWER**

POWER / FUSE / LINE VOLTAGE SELECTOR

The power chord is connected by a standardized coupling which comprises also the fuse, voltage selector and a line filter. With 230V AC the fuse must be 0.63A (slow), with 115V AC it must be 1.25A (slow).

CAUTION: (see also Safety Regulations)

- Always use a three-wire line cord and a mains power-plug with a protection contact connected to ground.
- Before opening the cabinet disconnect mains power-plug.
- Disconnect mains power-plug when replacing the fuse or changing line voltage.
- Replace fuse only with appropriate specified type.

- **SYNC. MODE CONNECTORS / SWITCH**

see Appendix "Synchronization of Two or More SEC Amplifier Systems"

REFERENCES

General

Brennecke, R. and Lindemann, B. (1971): A Chopped-Current Clamp for Current Injection and Recording of Membrane Polarization with Single Electrodes of Changing Resistance, T.I.T. Journal of Life Sciences, 1:53-58

Brennecke R, Lindemann B (1974) Theory of a membrane-voltage clamp with discontinuous feedback through a pulsed current clamp. Rev. Sci. Instrum. 45:184-188

Brennecke, R. and Lindemann, B. (1974): Design of a fast voltage clamp for biological membranes, using discontinuous feed-back, Rev. Sci. Instrum., 45:656-661

Brown, T.H. and Johnston, D. (1983): Voltage-Clamp Analysis of Mossy Fiber Synaptic Input to Hippocampal Neurons, J. Neurophysiol., 50:487-507

Dhein, St. (1998) Cardiac Gap Junction Channels, Physiology, Regulation, Patophysiology and Pharmacology, Karger, Basel

Dietzel, I. D., D. Bruns, H. R. Polder and H. D. Lux (1992) Voltage Clamp Recording, in Kettenmann, H. and R. Grantyn (eds.) Practical Electrophysiological Methods, Wiley-Liss, New York

Draguhn, A., Pfeiffer, M., Heinemann, U. and Polder, H.R. (1997) A simple hardware model for the direct observation of voltage-clamp performance under realistic conditions. J.Neurosci.Methods 78: 105-113.

Finkel AS, Gage PW (1985) Conventional Voltage Clamping With Two Intracellular Microelectrodes. In: Smith TG, Lecar H, Redman SJ, Gage PW (eds) Voltage and Patch Clamping With Microelectrodes. Chapter 4. The William and Wilkins Company, Baltimore, pp 47-94.

Finkel AS, Redman SJ (1985) Optimal Voltage Clamping With Single Microelectrode. In: Smith TG, Lecar H, Redman SJ, Gage PW (eds) Voltage and Patch Clamping With Microelectrodes. Chapter 5. The William and Wilkins Company, Baltimore, pp 95-120

Ferreira, H.H., and Marshall, M.W. (1985) The biophysical basis of excitability, Cambridge University Press, Cambridge

Fröhr F, Orthenburger F (1981) Introduction to Electronic Control Engineering. Siemens Aktiengesellschaft Berlin, Munich

Johnston, D. & Brown, T.H. (1983): Interpretation of Voltage-Clamp Measurements in Hippocampal Neurons, J. Neurophysiol., 50:464-486

Juusola, M (1994) Measuring complex admittance and receptor current by single electrode voltage-clamp. J. Neurosci. Meth. 53:1-6

Kettenmann H, and R Grantyn (eds). Practical Electrophysiological Methods Willey-Liss, New York (1992).

Misgeld U, Müller W, Polder HR (1989) Potentiation and suppression by eserine of muscarinic synaptic transmission in the guinea-pig hippocampal slice. *J. Physiol.* 409:191-206

Müller, A., M. Bachmann, R. Berkels, S. Dhein, H.R. Polder and W. Klaus (1998) Switched single electrode amplifiers allow precise measurement of gap junction conductance, *American Journal of Physiology*, in press

Ogden DC (1994) Microelectrode electronics. In Ogden, D.C. (ed.) (1994) Microelectrode techniques. The Plymouth Workshop Handbook. 2nd edition, The Company of Biologists Limited, Cambridge.

Polder HR (1984) Entwurf und Aufbau eines Gerätes zur Untersuchung der Membranleitfähigkeit von Nervenzellen und deren Nichtlinearität nach der potentiostatischen Methode (Voltage-Clamp-Methode) mittels einer Mikroelektrode, Diplomarbeit (M.Sc.EE thesis), Technische Universität München

Polder HR, Swandulla D, Konnerth A, and Lux HD (1984) An Improved, High Current Single Electrode Current/Voltage Clamp System, *Pflügers Archiv*, 402:R35

Polder HR, Swandulla D (1990) Design and optimal tuning of single and double electrode voltage clamp systems using methods of modulus hugging. *Pflügers Archiv* 415:S77

Polder, H.R., R. Schliephacke, W. Stühmer and H. Terlau (1997) A new, switched mode double electrode clamp amplifier avoiding series resistance errors, in Elsner, N. and H. Wässle (eds.) *Göttingen Neurobiology Report 1997*, Thieme Verlag Stuttgart

Polder, H.R. and Swandulla, D. (2001) The use of control theory for the design of voltage clamp systems: a simple and standardized procedure for evaluating system parameters. *J. Neuroscience Methods*, 109: 97-109

Richter, D.W., Pierrefiche, O., Lalley, P.M. and Polder, H.R. (1996) Voltage-clamp analysis of neurons within deep layers of the brain. *J.Neurosci.Methods* 67: 121-131.

Smith TG, Lecar H, Redman SJ, Gage PW (ed) Voltage and Patch Clamping With Microelectrodes. The William and Wilkins Company, Baltimore 1985

Weckström M, Kouvaleinen E., Juusola M (1992): Measurement of cell impedance in frequency domain using discontinuous current clamp and white-noise modulated current injection. *Pflügers Arch.* 421:469-472

Wilson, W.A. and Goldener, M.M. (1975): Voltage Clamping with a Single Microelectrode, *J. Neurobiol.*, 6:411-422

Selected Literature About the npi SEC 05/10 Single Electrode Clamp Systems

Recording Methods and Voltage Clamp Technique

Dietzel, I. D., D. Bruns, H. R. Polder and H. D. Lux (1992) Voltage Clamp Recording, in Kettenmann, H. and R. Grantyn (eds.) Practical Electrophysiological Methods, Wiley-Liss, NY.

Misgeld, U., W. Müller and H. R. Polder (1989) Potentiation and Suppression by Eserine of Muscarinic Synaptic Transmission in the Guinea-Pig Hippocampal Slice, *J.Physiol.*, 409: 191-206

Polder, H.R. and Swandulla, D. (2001) The use of control theory for the design of voltage clamp systems: a simple and standardized procedure for evaluating system parameters. *J. Neuroscience Methods*, 109: 97-109

Richter, D.W., Pierrefiche, O., Lalley, P.M. and Polder, H.R. (1996) Voltage-clamp analysis of neurons within deep layers of the brain. *J.Neurosci.Methods* 67: 121-131

Windhorst, U. and H. Johansson (eds.) Modern Techniques in Neuroscience Research, Springer, Berlin, Heidelberg, New York, 1999

Selection of switching frequency, electrode time constant, capacity compensation

Juusola, M (1994) Measuring complex admittance and receptor current by single electrode voltage-clamp. *J. Neurosci. Meth.* 53:1-6

Weckström M, Kouvaleinen E., Juusola M (1992): Measurement of cell impedance in frequency domain using discontinuous current clamp and white-noise modulated current injection. *Pflügers Arch.* 421:469-472

Comparison of recording methods (sharp electrode, whole cell, perforated patch)

Jarolimek, W. and U. Miseld (1993) 4-Aminopyridine-induced synaptic GABA-B currents in granule cells of the guinea-pig hippocampus, *Pflügers Arch* 425:491-498.

Kapur, M.F.Yeckel. R.Gray, and D. Johnston (1998) L-Type Calcium Channels Are Required for One Form of Hippocampal Mossy Fiber LTP, *J. Neurophysiol.* 77:2181-2190

Coating of sharp microelectrodes for VC recordings

Juusola, M., Seyfarth E.A. and French, A.S., (1997): Fast coating of glass-capillary microelectrodes for single-electrode voltage clamp, *J. Neurosci. Meth.* 71:199-204

Capacitive transients in VC recordings

Sutor, B., Hablitz, J.J. (1989): Excitatory postsynaptic potentials in rat neocortical neurons in vitro. I. Electrophysiological evidence for two distinct EPSPs. *Journal of Neurophysiology* 61, 607-620

Leak subtraction

Sutor, B., Zieglgänsberger, W. (1987): A low-voltage activated, transient calcium current is responsible for the time-dependent depolarizing inward rectification of rat neocortical neurons in vitro. *Pflügers Archiv* 410: 102-111

Cardiac cells / double cell voltage clamp method

Dhein, St. (1998) Cardiac Gap Junction Channels, Physiology, Regulation, Patophysiology and Pharmacology, Karger, Basel

Lu, J., J. F. Dalton, IV, D. R. Stokes, and R. L. Calabrese (1997) Functional role of Ca²⁺ currents in graded and spike- synaptic transmission between leech heart interneurons. *J. Neurophysiol.* **77**:1779–1794

Double Cell Recordings / Gap Junctions

Dhein, S., Wenig, S., Grover, R., Tudyka, T., Gottwald, M., Schaefer, T. & Polontchouk, L. (2002) Protein kinase Calpha mediates the effect of antiarrhythmic peptide on gap junction conductance. *Cell Adhes Commun*, **8**, 257-264.

Müller, A., M. Lauven, R. Berkels, S. Dhein, H.R. Polder and W. Klaus (1999) Switched single electrode amplifiers allow precise measurement of gap junction conductance, *American Journal of Physiology (Cell)* Vol. 276, No.4 C980-C988, April 1999

Weng, S., Lauven, M., Schaefer, T., Polontchouk, L., Grover, R. & Dhein, S. (2002) Pharmacological modification of gap junction coupling by an antiarrhythmic peptide via protein kinase C activation. *FASEB J.*, **16**, 1114-1116.

Simultaneous recordings with two SEC amplifiers

Haag, J, and A. Borst (1996) Amplification of high-frequency synaptic inputs by active dendritic membrane processes, *Nature* Vol 379, 639-641

Haag, J. and Borst, A. (2001). Recurrent Network Interactions Underlying Flow-Field Selectivity of Visual Interneurons. *J.Neurosci* **21** (15), 5685–5692.

Haag, J. and Borst, A. (2002). Dendro-Dendritic Interactions between Motion-Sensitive Large-Field Neurons in the Fly. *J.Neurosci* **22** (8), 3227–3233.

Simultaneous intracellular recordings during voltammetric measurements

Kudernatsch, M., Sutor, B.: Cholinergic modulation of dopamine overflow in the rat neostriatum: a fast cyclic voltammetric study in vitro. *Neuroscience Letters* 181, 107-112, 1994.

Schlösser, B., Kudernatsch, M.B., Sutor, B., ten Bruggencate, G. (1995): d -, m - and k -opioid receptor agonists inhibit dopamine overflow in rat neostriatal slices. *Neuroscience Letters* 191, 126-130,

Staining, visualization, imaging and infrared video microscopy

Dotd, H.U and W. Zieglgänsberger (1994) Infrared videomicroscopy: a new look at neuronal structure and functure, *Trends in Neurosciences*, Vol. 19 No. 11 453-458

Kapur A., M. Yeckel and D. Johnston (2001) Hippocampal mossy fiber activity evokes Ca²⁺ release in CA3 pyramidal neurons via a metabotropic glutamate receptor pathway, *Neuroscience* **107** (1):59-69

Röhrig, G., Klaus, G., and Sutor, B. (1996) Intracellular acidification reduced gap junction coupling between immature rat neocortical pyramidal neurons, *Journal of Physiology* 490.1 pp. 31-49

Single, S. and A. Borst (1998) Dendritic Integration and Its Role in Computing Image Velocity, *Science*. Vol. 281:1848-50

Single, S. and Borst, A. (2002) Different Mechanisms of Calcium Entry Within Different Dendritic Compartments. *J.Neurophysiol.* **87**, 1616–1624.

Performance test with active cell model

Draguhn, A., Pfeiffer, M., Heinemann, U. and Polder, H.R. (1997) A simple hardware model for the direct observation of voltage-clamp performance under realistic conditions. *J. Neurosci. Methods* **78**: 105-113.

Hybrid Clamp

Dietrich, D., Clusmann, H. and T. Kral (2002). Improved hybrid clamp: resolution of tail currents following single action potentials. *J.Neurosci.Meth.* **116**, 55-63.

LTP / LDP Investigations

Blank, T., Nijholt, I., Eckart, K., and Spiess, J. (2002). Priming of long-term potentiation in mouse hippocampus by corticotropin-releasing factor and acute stress: implications for hippocampus-dependent learning. *J.Neurosci* **22**:3788-94.

Dotz, H., Eder, M., Frick, A., and Zieglgansberger, W. (1999). Precisely localized LTD in the neocortex revealed by infrared-guided laser stimulation. *Science* **286**, 110-113.

Eder, M., Zieglgansberger, W., & Dotz, H. U. (2002). Neocortical long-term potentiation and long-term depression: site of expression investigated by infrared-guided laser stimulation. *J.Neurosci.* **22**, 7558-7568.

Marsicano, G., Wotjak, C. T., Azad, S. C., Bisognok, T., Rammes, G., Casciok, M. C., Hermann, H., Tang, J., Hofmann, C., Zieglgansberger, W., Di Marzok, V. & Lutz, B. (2002). The endogenous cannabinoid system controls extinction of aversive memories. *Nature* **418**, 530-533.

Nakazawa K., Quirk, M. C., Chitwood, R. A., Watanabe, M., Yeckel, M. F., Sun, L. D., Kato, A., Carr, C. A., Johnston, D., Wilson, M. A. & Tonegawa, M. A. (2002). Requirement for Hippocampal CA3 NMDA Receptors in Associative Memory Recall. *Science* **297**, 211-218.

Rammes, G., Steckler, T., Kresse, A., Schutz, G., Zieglgansberger, W., and Lutz, B. (2000). Synaptic plasticity in the basolateral amygdala in transgenic mice expressing dominant-negative cAMP response element-binding protein (CREB) in forebrain. *Eur.J.Neurosci.* **12**, 2534-2546.

Intra- and extracellular recording

Sillaber, I., Rammes, G., Zimmermann, S., Mahal, B., Zieglgansberger, W., Wurst, W., Holsboer, F. & Spanagel, R. (2002). Enhanced and Delayed Stress-Induced Alcohol Drinking in Mice Lacking Functional CRH1 Receptors. *Science* **296**, 931-933.

Perforated Patch

Hanganu, I. L., Kilb, W., & Luhmann, H. J. (2002). Functional synaptic projections onto subplate neurons in neonatal rat somatosensory cortex. *J.Neurosci.* **22**, 7165-7176.

Selected Literature Voltage & Patch Clamp Techniques

Publications in scientific journals:

Armstrong, C.M. and Chow, R.H. (1987) Supercharging: A method for improving patch-clamp performance. *Biophys.J.* 52: 133-136.

Bekkers, J.M. and Stevens, C.F. (1996) Cable properties of cultured hippocampal neurons determined from sucrose-evoked miniature EPSCs. *J.Neurophysiol.* 75: 1250-1255.

Blanton, M.G., Lo Turco, J.J. and Kriegstein, A.R. (1989) Whole cell recording from neurons in slices of reptilian and mammalian cerebral cortex. *J.Neurosci.Meth.*30:203-10.

Brennecke, R. and Lindemann, B. (1974) Theory of a membrane-voltage clamp with discontinuous feedback through a pulsed current clamp. *Rev.Sci.Instrum.* 45: 184-188.

Bush, P.C. and Sejnowsky, T.J. (1993) Reduced compartmental models of neocortical pyramidal cells. *J.Neurosci.Methods* 46: 159-166.

De Schutter, E. and Bower, J.M. (1994) An active membrane model of the cerebellar purkinje cell: II. Simulation of synaptic responses. *J.Neurophysiol.* 71: 401-419.

Draguhn, A., Pfeiffer, M., Heinemann, U. and Polder, H.R. (1997) A simple hardware model for the direct observation of voltage-clamp performance under realistic conditions. *J.Neurosci.Methods* 78: 105-113.

Edwards, F.A., Konnerth, A., Sakmann, B. and Takahashi, T. (1989) A thin slice preparation for patch clamp recordings from neurons of the mammalian nervous system. *Pflügers Arch.* 414: 600-612.

Eisenberg, R.S. and Engel, E. (1970) The spatial variation of membrane potential near a small source of current in a spherical cell. *J. Gen. Physiol.* 55:736-757.

Engel, E., Barcilon, V. and Eisenberg, R.S. (1972) The interpretation of current-voltage relations recorded from a spherical cell with a single microelectrode. *Biophys. J.* 12:384-403.

Gorman, A.L.F. and Mirolli, M. (1972) The passive electrical properties of the membrane of a molluscan neurone. *J. Physiol.* 227:35-49.

Hamill, O.P., Marty, A., Neher, E., Sakmann, B. and Sigworth, F.J. (1981) Improved patch-clamp techniques for high-resolution current recording from cells and cell-free membrane patches. *Pflügers Arch.* 391: 85-100.

Henze, D.A., Cameron, W.E. and Barrionuevo, G.N. (1996) Dendritic morphology and its effects on the amplitude and rise-time of synaptic signals in hippocampal CA3 pyramidal cells. *J.Comp.Neurol.* 369: 331-344.

- Jackson, M.B. (1992) Cable analysis with the whole-cell patch clamp. Theory and experiment. *Biophys.J.* 61: 756-766.
- Johnston, D. (1981) Passive cable properties of hippocampal CA3 pyramidal neurons. *Cell. Mol. Neurobiol.* 1: 41-55.
- Johnston, D. and Brown, T.H. (1983) Interpretation of voltage-clamp measurements in hippocampal neurons. *J.Neurophysiol.* 50: 464-486.
- Kawato, M. (1984) Cable properties of a neuron model with non-uniform membrane resistivity. *J. Theor. Biol.* 111: 149-169.
- Mainen, Z.F. and Sejnowski, T.J. (1996) Influence of dendritic structure on firing pattern in model neocortical neurons. *Nature* 382: 363-366.
- Magistretti, J., Mantegazza, M., Guatteo, E. and E. Wanke (1996). Action potentials recorded with patch-clamp amplifiers: are they genuine? *Trends Neurosci.* **19**, 530-534
- Major, G. (1993) Solutions for transients in arbitrarily branching cables: III. Voltage clamp problems. *Biophys.J.* 65: 469-491.
- Müller, W. and Lux, H.D. (1993) Analysis of voltage-dependent membrane currents in spatially extended neurons from point-clamp data. *J.Neurophysiol.* 69: 241-247.
- Polder, H.R. and Swandulla, D. (1990) Design and optimal tuning of single and double electrode voltage clamp systems using methods of modulus hugging. *Pflügers Arch.* 415: S77.
- Polder, H.R., Swandulla, D., Konnerth, A. and Lux, H.D. (1984) An improved high current single electrode current/voltage clamp system. *Pflügers Arch.* 406: R43.
- Polder, H.R. and Swandulla, D. (2001) The use of control theory for the design of voltage clamp systems: a simple and standardized procedure for evaluating system parameters. *J. Neuroscience Methods*, 109: 97-109
- Rall, W. (1959) Branching dendritic trees and motoneuron resistivity. *Exp. Neurol.* 1: 491-527.
- Rall, W (1969) Time constants and electrotonic length of membrane cylinders and neurons. *Biophys. J.* 9: 1483-1508.
- Richter, D.W., Pierrefiche, O., Lalley, P.M. and Polder, H.R. (1996) Voltage-clamp analysis of neurons within deep layers of the brain. *J.Neurosci.Methods* 67: 121-131.
- Sala, F. and Sala, S. (1994) Sources of error in single-electrode voltage-clamp techniques: a computer simulation study. *J.Neurosci.Methods* 53: 189-197.
- Spruston, N., Jaffe, D.B., Williams, S.H. and Johnston, D. (1993) Voltage- and space-clamp errors associated with the measurement of electrotonically remote synaptic events. *J.Neurophysiol.* 70: 781-802.

- Spruston, N. and Johnston, D. (1992) Perforated patch-clamp analysis of the passive membrane properties of three classes of hippocampal neurons. *J. Neurophysiol.* 67: 508-529.
- Staley, K.J., Otis, T.S. and Mody, I. (1992) Membrane properties of dentate gyrus granule cells: Comparison of sharp microelectrode and whole-cell recordings. *J. Neurophysiol.* 67: 1346-1358.
- Silver, R.A., Traynella, S.F. and Cull-Candy, S.G. (1992) Rapid time-course miniature and evoked excitatory currents at cerebellar synapses *in situ*. *Nature* 355: 163-166.
- Williams, S.H. and Johnston, D. (1991) Kinetic properties of two anatomically distinct excitatory synapses in hippocampal CA3 pyramidal neurons. *J. Neurophysiol.* 66: 1010-1020.
- Wilson, W.A. and Goldner, M.M. (1975) Voltage clamping with a single microelectrode. *J. Neurobiol.* 6: 411-422.

Book chapters :

Armstrong, C. M. and Gilly, W.F. (1992) Access resistance and space clamp problems associated with whole-cell patch clamping. In: *Methods in enzymology*. Vol. 207, Academic Press, San Diego, CA, USA.

Dietzel, I. D., Bruns, D., Polder, H. R. and Lux, H. D. (1992) Voltage clamp recording. In: Kettenmann, H. and Grantyn, R. (eds.) *Practical electrophysiological methods*. Wiley-Liss, NY.

Eisenberg, R.S. and Johnson, E.A. (1970) Three-dimensional electrical field problems in physiology. In: Butler, J.V.A. and Noble, D. (eds.) *Progress in Biophysics and Molecular Biology*, Vol. 20, Pergamon Press, Oxford, p 1.

Finkel, A.S. and Gage, P.W. (1985) Conventional voltage clamping with two intracellular microelectrodes. In: Smith, T.G., Lecar, H., Redman, S.J. and Gage, P.W. (eds.) *Voltage and patch clamping with microelectrodes*. Chapter 4. The William and Wilkins Company, Baltimore, p 47.

Finkel, A.S. and Redman, S.J. (1985) Optimal voltage clamping with single microelectrode. In: Smith, T.G., Lecar, H., Redman, S.J. and Gage, P.W. (eds.) *Voltage and patch clamping with microelectrodes*. Chapter 5. The William and Wilkins Company, Baltimore, p 95.

Jack, J. (1979) An introduction to linear cable theory. In: Scmitt, F.O. and Worden, F.G. (eds.) *The Neurosciences, Fourth Study Program*. MIT Press, Cambridge, p 423.

Marty, A. and Neher, E. (1995) Tight-seal whole-cell recording. In: Sakmann, B. and Neher, E. (eds.) *Single channel recording*. 2nd edition, Plenum Press, New York.

Ogden, D. and Stanfield, P. (1994) Patch clamp techniques for single channel and whole-cell recording. In: Ogden, D. (ed.) *Microelectrode techniques*. 2nd edition, The Company of Biologists Ltd., Cambridge.

Rall, W. (1977) Core conductor theory and cable properties of neurons. In: Kandel, E.R. (ed.) *Handbook of Physiology, Section I, The Nervous System, Volume I, Part I*, American Physiological Society, Bethesda, p. 39

Sigworth, F.J. (1995) Electronic design of the patch-clamp. In: Sakmann, B. and Neher, E. (eds.) *Single channel recording*. 2nd edition, Plenum Press, New York.

Whole books:

Boulton, A.A., Baker, G.B. and Vanderwolf, C.H. (eds.) (1990) Neurophysiological techniques. Basic methods and concepts. Humana Press, Clifton, New Jersey.

Cole, K.S. (1968) Membranes ions and impulses. University of California Press, Berkely, CA.

Ferreira, H.G. and Marshall, M.W. (1985) The biophysical basis of excitability. Cambridge University Press, Cambridge.

Fröhr, F. (1985) Electronic control engineering made easy. An introduction for beginners. Siemens AG, Berlin and Munich.

Horowitz, P. and Hill, W. (1989) The art of electronics. Cambridge University Press, NY

Jack, J.J.B., Noble, D. and Tsien, R.W. (1975) Electric current flow in excitable cells. Clarendon Press, Oxford.

Kettenmann, H. and Grantyn, R. (eds.) (1992) Practical electrophysiological methods. Wiley-Liss, New York.

Neher, E. (1974) Elektrische Meßtechnik in der Physiologie. Springer-Verlag, Berlin.

Numberger, M. and Draguhn, A. (eds.) (1996) Patch-Clamp-Technik. Spektrum Akad. Verl., Heidelberg, Berlin, Oxford.

Ogden, D.C. (ed.) (1994) Microelectrode techniques. The Plymouth Workshop Handbook. 2nd edition, The Company of Biologists Limited, Cambridge.

Polder, H.R. (1984) Entwurf und Aufbau eines Gerätes zur Untersuchung der Membranleitfähigkeit von Nervenzellen und deren Nichtlinearität nach der potentiostatischen Methode (Voltage-Clamp-Methode) mittels einer Mikroelektrode. Diplomarbeit, Technische Universität München.

Rudy, B. and Iverson, L.E. (eds.) (1992) Ion channels. In: Methods in enzymology. Vol. 207, Academic Press, San Diego, CA, USA.

Sahm III, W.H. and Smith, M.W. (eds.) (1984) Optoelectronics manual. 3rd edition, General Electric Company, Auburn, NY, USA.

Sakmann, B. and Neher, E. (eds.) (1995) Single channel recording. 2nd Edition, Plenum.NY,.

Smith, T.G., Jr., Lecar, H., Redmann, S.J. and Gage, P.W. (eds.) (1985) Voltage and patch clamping with microelectrodes. American Physiological Society, Bethesda; The Williams & Wilkins Company, Baltimore.

Windhorst, U. and H. Johansson (eds.) Modern Techniques in Neuroscience Research, Springer, Berlin, Heidelberg, New York, 1999

**OPERATING INSTRUCTIONS AND
SYSTEM DESCRIPTION FOR THE**

PASSIVE CELL MODEL

**FOR SINGLE ELECTRODE-,
PATCH CLAMP- AND BRIDGE
AMPLIFIERS**

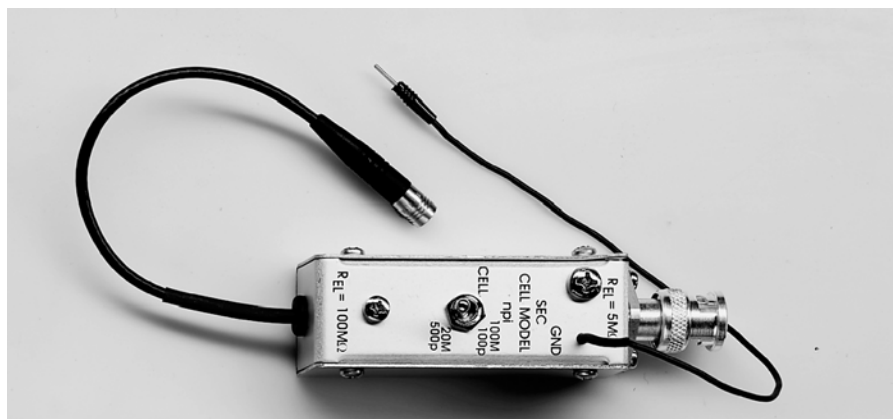

VERSION 2.2
npi 2002

1. Introduction

The cell model is designed to be used to check the function of the instrument either

1. just after unpacking to see whether the instrument has been damaged during transport or
2. to train personnel in using the instrument or
3. in case of trouble to check which part of the setup does not work correctly e.g. to find out whether the amplifier is broken or if something is wrong with the electrodes or holders etc.

This cell model consist only of passive elements i.e. resistors that simulate the resistance of the cell membrane and the electrodes and capacitances that simulate the capacitance of the cell membrane (see Figure 2). A switch allows to simulate two different cell types: a “small” cell with 100 M Ω membrane resistance and 100 pF membrane capacitance or a “large” cell with 20 M Ω and 500 pF. The headstage of the amplifier can be connected to one of two different types of electrodes (see below).

2. Cell Model Description

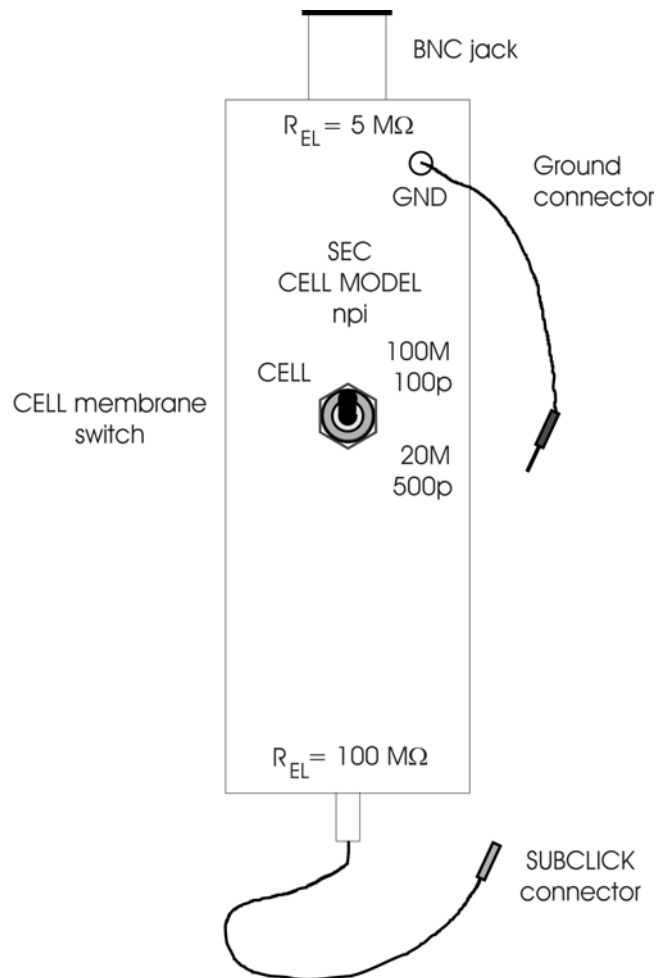
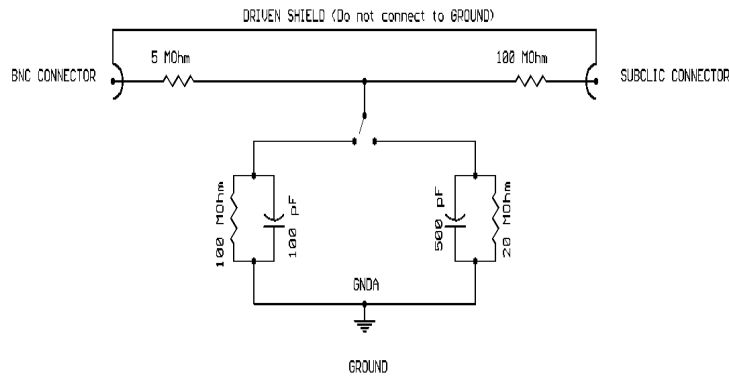

Figure 1: SEC passive cell model

- R_{EL} BNC: connector for the “patch” electrode, resistance: 5 M Ω
 GND: ground connector
 CELL: switch for cell membrane representing a membrane of either 100 M Ω and 100 pF or 20 M Ω and 500 pF
 R_{EL} SUBD: connector for the “sharp” electrode, resistance: 100 M Ω

SIMULATION OF WHOLE CELL RECORDING

SIMULATION OF SHARP MICROELECTRODE RECORDING



SEC / BA-1S / BRAMP CELL MODEL

Figure 2: schematic diagram of the passive cell model

3. Connections and Operation

3.1. Checking the Configuration with the Cell Model

- Turn POWER switch of the amplifier off.
- a) For simulation of an experiment using a “suction electrode”
 - Connect the BNC jack of the cell model to the BNC connector MICROELECTRODE of the headstage.
- b) For simulation of an experiment using a “sharp electrode”
 - Connect SUBCLICK connector of the cell model to the BNC connector at the headstage.

For a) and b)

- Connect GND of the cell model to GND of the headstage.
- Leave REF untouched.
- Switch the CELL membrane switch (see Figure 1) to the desired position.
- Turn all controls at the amplifier to low values (less than 1) and the OFFSET in the range of 5.

- ❑ Turn POWER switch of the amplifier on.

Now you can adjust the amplifier and apply test pulses to the cell model. Connection to the BNC jack gives access to the cell via an electrode with 5 M Ω resistance. Connection to SUBD adapter simulates access to the cell via an electrode with 100 M Ω resistance. The upper position the CELL membrane switch simulates “small” cell with a resistance of 100 M Ω and a capacitance of 100 pF. In the lower position a “large” cell membrane with 20 M Ω and 500 pF is simulated.

APPENDIX

TUNING CAPACITY COMPENSATION IN SEC AMPLIFIER SYSTEMS

VERSION 1.11 –NPI 2002

For accurate measurements in switched mode, it is essential that the capacity of the electrode is fully compensated.

Important: Wrong compensation of electrode capacity leads to errors in measurements done in switched mode of the amplifier (see Figure 2).

Microelectrode selection: Electrodes must be tested before use. This is done by applying positive and negative current pulses. Electrodes that show significant changes in resistance (rectification) cannot be used for intracellular recordings. By increasing the current amplitude the capability of the electrode to carry current can be estimated. The test current must cover the full range of currents used in the experiment. For details see (3).

Switching frequency is a key parameter of discontinuous single electrode clamp (dSEVC) systems. The switching frequency determines the accuracy, speed of response, and signal-to noise ratio of the dSEVC system (3)(6). Since its launch in 1984, one of the outstanding features of the SEC series of single electrode voltage / current clamp systems has been the ability to record routinely with high switching frequencies in the range of tens of kilohertz, regardless of the microelectrode resistance (1). Principles of the dSEVC technique are found in (1)(2).

Looking back: In the early eighties, when the design of the SEC 1L system was started, single electrode clamping began to gain importance beside the two classical intracellular methods: bridge recording or whole cell patch clamp recording. The great advantage compared to the whole cell recording method using a patch amplifier was the elimination of series resistance due to the time sharing protocol. No current flow during voltage recording means no interference from the series resistance regardless of its value. Voltage clamp recordings became possible with sharp microelectrodes in deep cell layers. The historical weak point of this method was the low switching frequency due to the fact that stray capacities around the microelectrode could not be compensated sufficiently.

The SEC systems provided a solution for this problem. With their improvements on capacity compensation electronics, they could be used with switching frequencies of tens of kHz even with high resistance microelectrodes. What are the technical principles that make possible such high switching frequencies?

In SEC systems a special protocol is used to rapidly compensate the microelectrode. Figure 1 shows the compensation scheme of a sharp microelectrode immersed 3 mm in cerebrospinal fluid. Here the increase in speed can be seen clearly. Recordings under such conditions and possible applications have been presented in several papers (e.g. (3)).

Criteria for the selection of the switching frequency

Which are the most important criteria for the selection of the switching frequency? This question was analyzed in detail by M. Weckstrom and colleagues (4)(5). They presented a formula that describes the conditions for obtaining reliable results during a switching single electrode clamp:

$$f_c > 3f_{sw}, f_{sw} > 2f_s, f_s > 2f_f > f_m$$

- f_c : upper cutoff frequency of the microelectrode
- f_{sw} : switching frequency of the dSEVC
- f_s : sampling frequency of the data acquisition system
- f_f : upper cutoff frequency of the lowpass filter for current recording,
- f_m : upper cutoff frequency of the membrane.

Example (6): With the time constant of 1-3 μ s recorded for the electrodes used in this study, f_c is 80-160 kHz, the selected switching frequency of the dSEVC was 30 - 50kHz (calculated range is 25-53 kHz), data were sampled at 10 kHz and the current signals have been filtered at 5 kHz. These settings are currently used for recordings in many labs.

The principle of operation in switched mode is shown below.

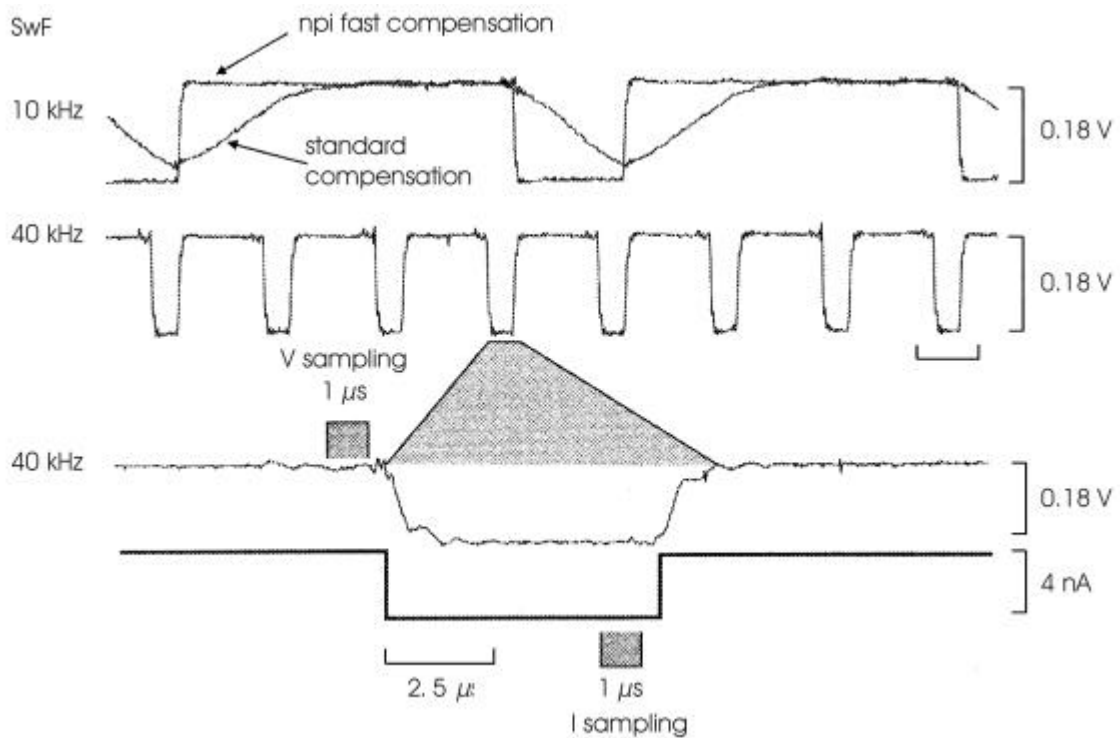

Figure 1: Microelectrode artifact settling.

Compensation of stray capacities with a SEC 05 amplifier. The upper trace shows the comparison between the standard capacity compensation and the fast compensation of the SEC systems. After full compensation the settling time of the microelectrode is reduced to a few microseconds allowing very high switching frequencies (here: 40 kHz, middle and lower trace). The microelectrode was immersed 3 mm deep in cerebrospinal fluid. Microelectrode resistance: 45 M Ω , current: 1 nA, duty cycle 25%. SwF: switching frequency.

Original data kindly provided by Prof. Diethelm W. Richter, Goettingen. For details see (3).

Tuning Capacity Compensation

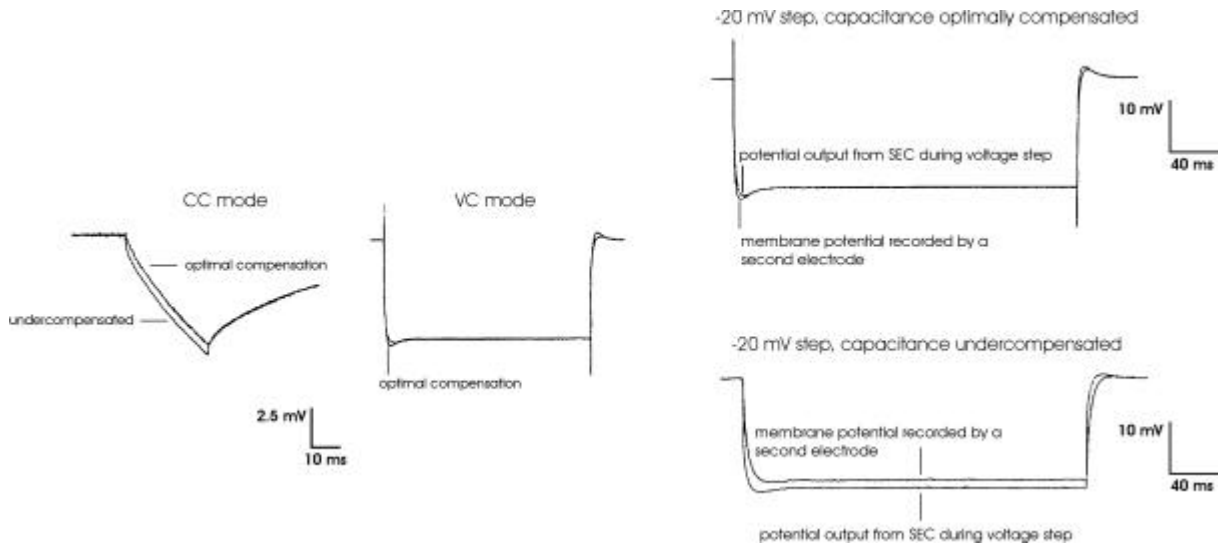

Figure 2: Errors resulting from wrong compensation of the electrode capacity. Original data kindly provided by Ajay Kapur. For details see (7).

Tuning Procedure (see also chapter “Getting Started”, pages 14, 15):

First part: basic setting

In SEC systems the capacity compensation of the electrode is split into two controls, the coarse control in the headstage and a the fine control at the front panel of the amplifier. The aim of the first part of the tuning procedure is to set the coarse capacity compensation at the headstage, so that an optimal, wide range of CAP.COMP. at the amplifier is achieved.

- ❑ Insert the electrode into the electrode holder and connect it to the amplifier.
- ❑ Immerse the electrode, as deep as it will be during the experiment, into the bath solution.
- ❑ Set the CAP.COMP. control at the amplifier (potentiometer #24 at the front panel) to a value around 2 and turn COARSE CAPACITY COMPENSATION at the headstage to the leftmost position. Select a DUTY CYCLE as desired (#24 at the front panel).
- ❑ Connect the BNC connector ELECTRODE POTENTIAL OUTPUT at the rear panel to an oscilloscope and trigger with the signal at BNC connector SWITCHING FREQUENCY (also at the rear panel). The oscilloscope should be in external trigger mode. The time base of the oscilloscope should be in the range of 250 μ s.
- ❑ Set the amplifier in CC mode and select the lowest switching frequency (1 to 2 kHz)
- ❑ Apply positive or negative current to the electrode using the HOLDING CURRENT control (potentiometer #21 at the front panel).
- ❑ You should see a signal at the oscilloscope similar to those in Figure 3. Turn the COARSE CAPACITY COMPENSATION carefully clockwise until the signal becomes as square as possible (lower diagram in Figure 3).

Important: If you use a model cell (e.g. to train yourself in adjusting the capacity compensation) the capacity of the model cell is always present. Thus, you will get an approximately square shaped signal with a slight slope as shown in Figure 4 (lower panel).

- ❑ Increase the switching frequency to at least 15 kHz. The amplitude and shape of the signal should not change considerably.

Tuning Capacity Compensation

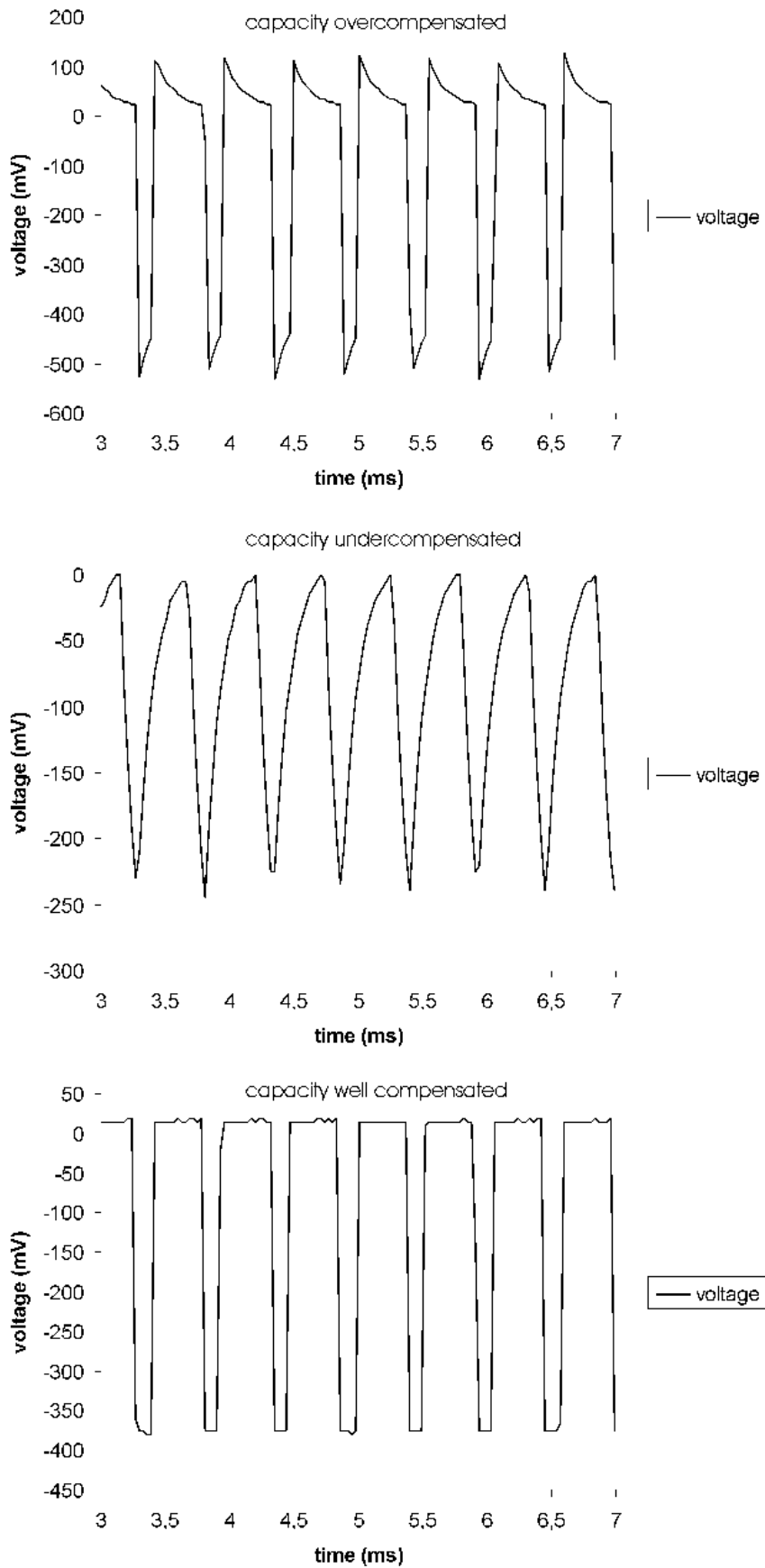

Figure 3: Tuning of the coarse capacity compensation with an electrode (resistance $100\text{ M}\Omega$) in the bath. Time course of the signal at ELECTRODE POTENTIAL OUTPUT is shown (holding current: -1 nA , duty cycle: $\frac{1}{4}$ switching frequency: 2 kHz).

Tuning Capacity Compensation

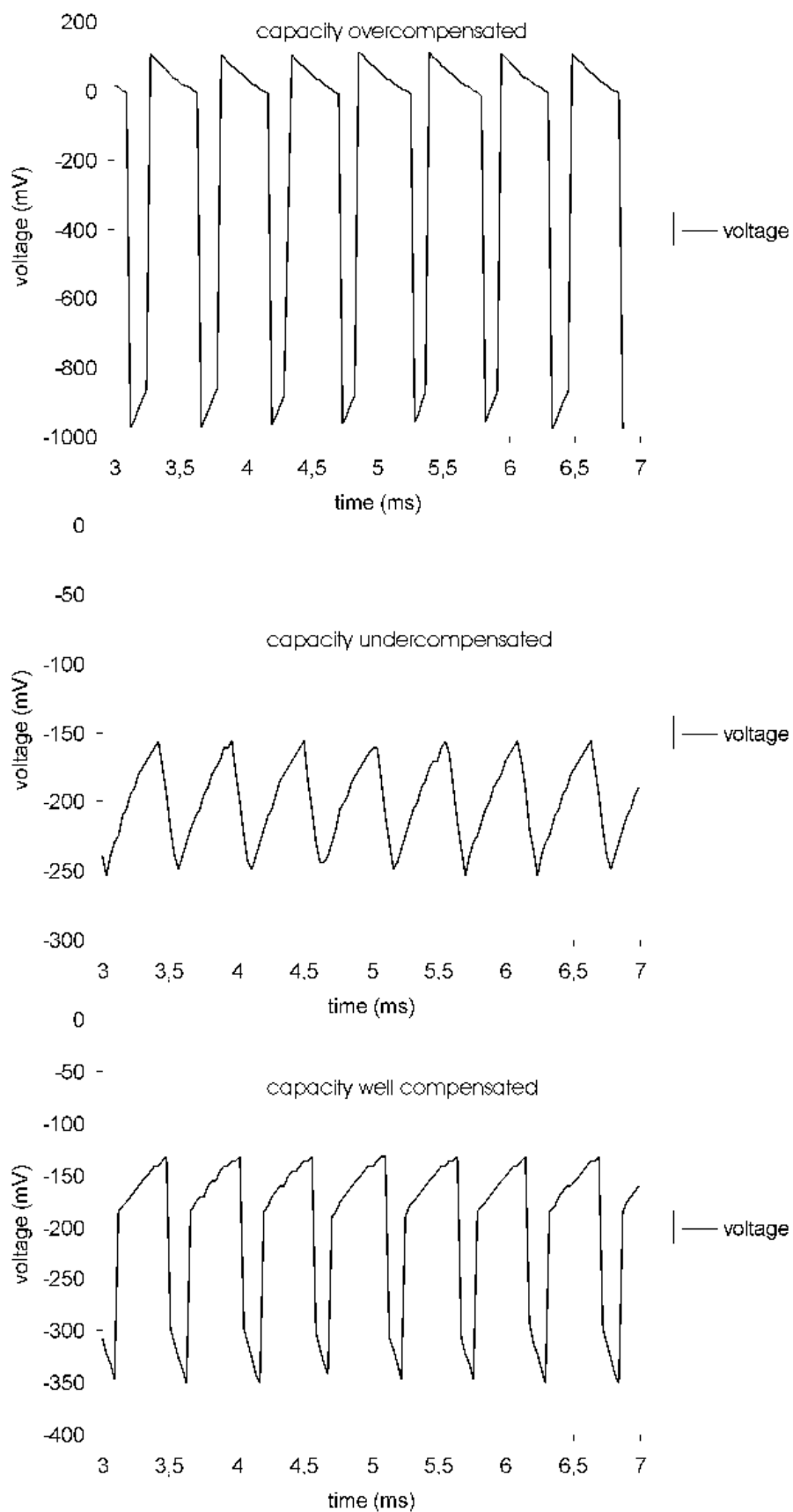

Figure 4: Tuning of the coarse capacity compensation. Time course of the signal at ELECTRODE POTENTIAL OUTPUT is shown (holding current: -1 nA, duty cycle: $\frac{1}{4}$ switching frequency: 2 kHz). A model cell was connected (electrode resistance 100 M Ω).

Tuning Capacity Compensation

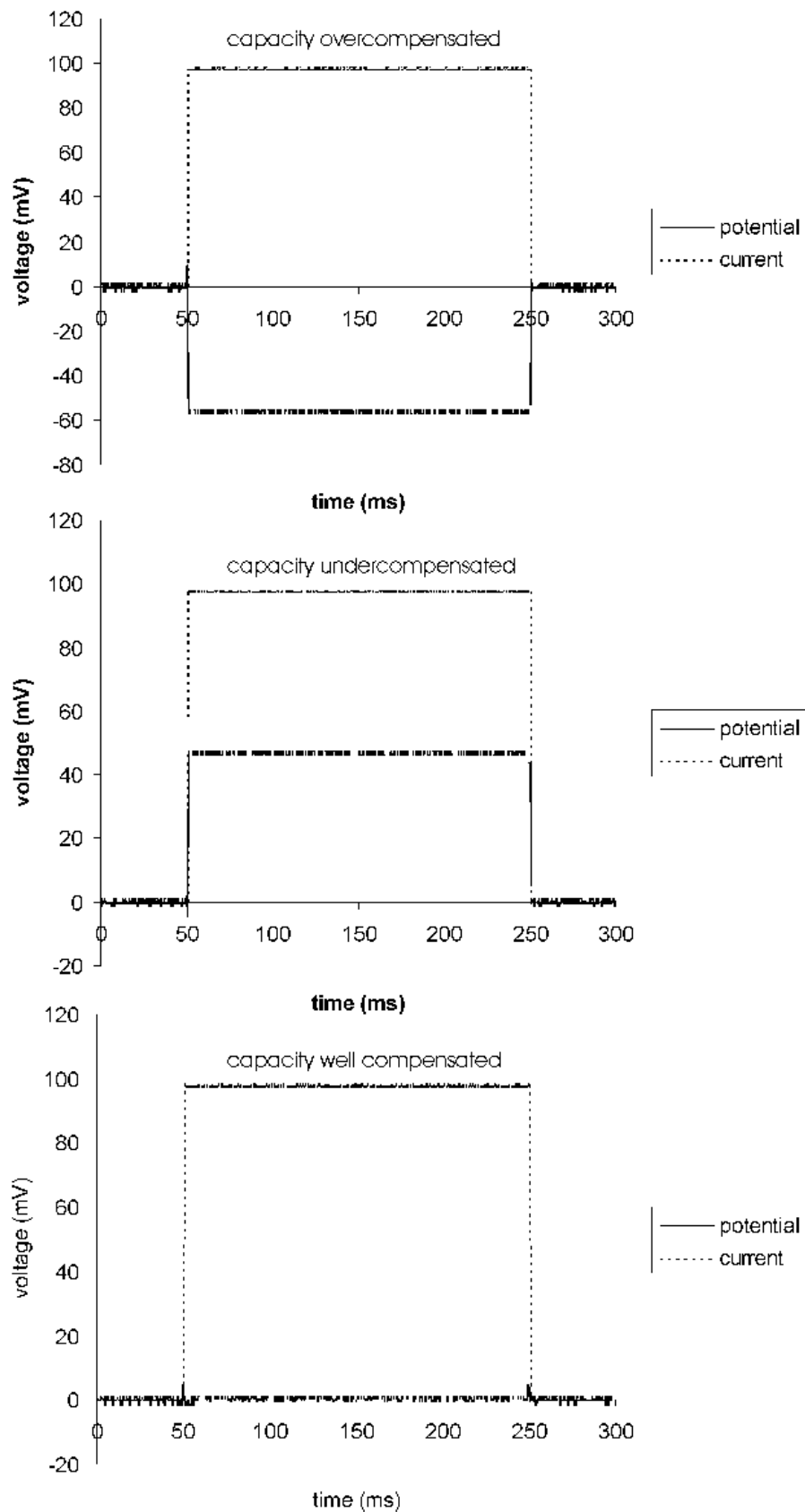

Figure 5: Capacity compensation of the electrode in the bath (electrode resistance: $100 \text{ M}\Omega$, Current stimulus: 1 nA , duty cycle: $\frac{1}{4}$ switching frequency: 2 kHz). Current stimulus and electrode potential are shown.

Tuning Capacity Compensation

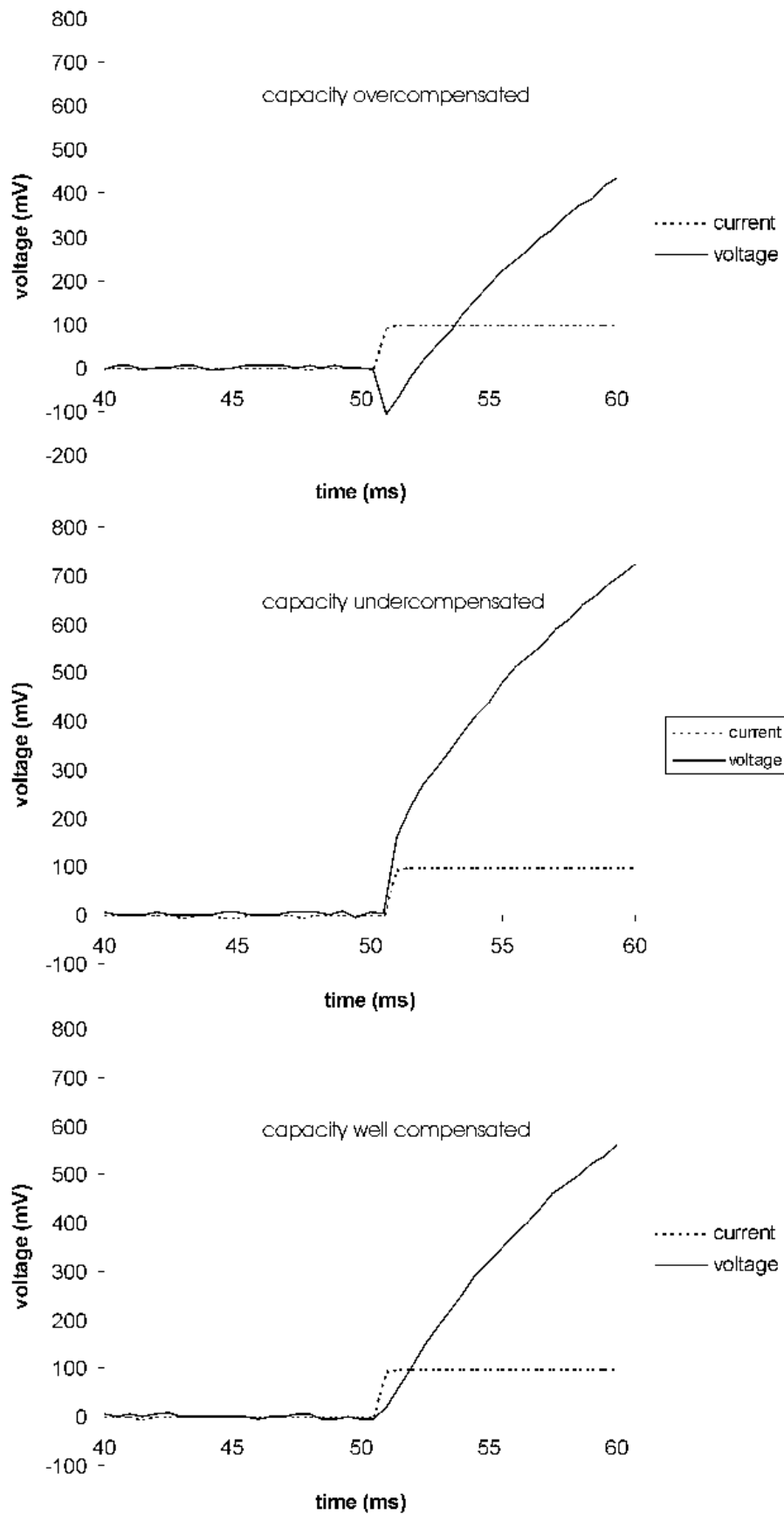

Figure 6: Capacity compensation of the electrode using a model cell (electrode resistance: $100\text{ M}\Omega$, current: 1 nA , cell membrane: $100\text{ M}\Omega$, 100 pF , duty cycle: $\frac{1}{4}$ switching frequency: 2 kHz). Current stimulus and membrane potential are shown.

Second part: fine tuning

Now the basic setting of the CAPACITY COMPENSATION is achieved. Since the electrode parameters change during the experiment (especially after impaling a cell), it is necessary to fine tune the CAPACITY COMPENSATION during the experiment using the CAP.COMP. control on the amplifier. To get familiar with this, connect a cell model and go through the following steps (the procedure is the identical with a “real” cell).

- ❑ Connect POTENTIAL OUTPUT and CURRENT OUTPUT (front panel) to another oscilloscope.
- ❑ Set SWITCHING FREQUENCY to the desired value (>15 kHz) and DUTY CYCLE to the desired value.
- ❑ Set the HOLDING CURRENT to zero. With the amplifier in CC mode, apply square pulses of a few nA (or a few tens of pA for patch recordings) to the cell. Negative current pulses are recommended. If you apply positive current pulses, be sure only to elicit ohmic responses of the cell membrane, i.e. pulses should not elicit openings of voltage gated channels.
- ❑ The POTENTIAL OUTPUT should show the ohmic response of the cell membrane, without an artifact, as illustrated in Figure 6 and Figure 7.

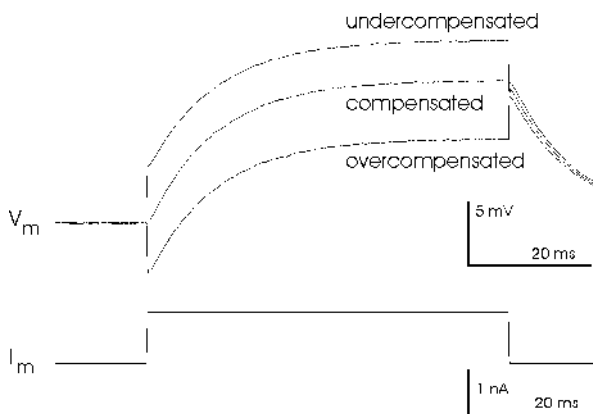

Figure 7: Capacity compensation of the electrode inside a cell. Current stimulus and membrane potential are shown.

Hint: The results of this procedure look very similar to tuning of the bridge balance. If the BRIDGE is balanced accurately no differences in the potential outputs should occur when switching between CC- and BRIDGE mode.

Important: Always monitor the OUTPUT from ELECTRODE POTENTIAL OUTPUT at the rear panel, using a second oscilloscope. The signals must be always square. If not, CAPACITY COMPENSATION has to be readjusted or the switching frequency must be lowered.

References:

- (1) Polder, H. R., Swandulla, D., Konnerth, A., & Lux, H. D. (1984). An Improved High Current Single-Electrode Voltage/Current Clamp System. *Pflugers Arch.* **402**, R35.
- (2) Polder, H. R., & Swandulla, D. (2001). The use of control theory for the design of voltage clamp systems: a simple and standardized procedure for evaluating system parameters. *J.Neurosci. Methods* **109**, 97-109.
- (3) Richter, D. W., Pierrefiche, O., Lalley, P. M., & Polder, H. R. (1996). Voltage-clamp analysis of neurons within deep layers of the brain. *J.Neurosci. Methods* **67**,121-131.
- (4) Juusola, M. (1994). Measuring complex admittance and receptor current by single electrode voltage-clamp. *J.Neurosci. Methods* **53**, 1-6.
- (5) Weckstrom M., Kouvaleinen E., & Juusola M. (1992). Measurement of cell impedance in frequency domain using discontinuous current clamp and white-noise modulated current injection. *Pflugers Arch.* **421**, 469-472.
- (6) Muller, A., Lauven, M., Berkels, R., Dhein, S., Polder, H. R., & Klaus, W. (1999). Switched single electrode amplifiers allow precise measurement of gap junction conductance. *Amer.J.Physiol. (Cell)* **276** (4), C980-C988.
- (7) Kapur, A., Yeckel, M. F., Gray, R., & Johnston, D. (1998). L-Type calcium channels are required for one form of hippocampal mossy fiber LTP. *J.Neurophysiol.* **79**, 2181-2190.
- (8) Torkkeli, P. H., Sekizawa, S., & French, A. S. (2001). Inactivation of voltage-activated Na(+) currents contributes to different adaptation properties of paired mechanosensory neurons. *J.Neurophysiol.* **85**, 1595-1602.

For more information please contact:

support@npielectronic.com

SYNCHRONIZATION OF TWO OR MORE SEC AMPLIFIER SYSTEMS

For recordings with two or more switched mode amplifiers in the same preparation it is necessary to synchronize the current injection and voltage recording timing protocols to avoid artifacts and excessive noise. This is done by the synchronization inputs and outputs at the rear panel of the instruments based on a "master-slave" arrangement.

The MASTER instrument provides the clock frequency (from which the switching frequency is generated internally) for the SLAVE instruments.

The MASTER instrument has a BNC connector marked SYNC. OUTPUT (TTL). To this output the SLAVE instruments are connected by means of standard BNC cables.

The SLAVE instruments have a SYNC. INPUT (TTL) BNC connector and a toggle switch marked "INTERN / EXTERN". In the position EXTERN the instrument is used with the clock frequency of the MASTER instrument i.e. in SLAVE mode. In the position INTERN the instrument can be used independently of the MASTER instrument.

Warning: If this switch is in the EXTERN position and no signal is connected to the SYNC. INPUT BNC the switched modes of the amplifier (VC and CC) are not working (no switching frequency!).

In the EXTERN position and with the MASTER instrument connected, in both switched modes (VC / CC) the switching frequency is controlled by the MASTER amplifier. In this case current injection and sampling of current and potential signals is synchronous, therefore all artifacts are suppressed.

Important: All synchronized instruments must use the same duty cycle!

Literature:

- Dhein, St., Double Cell Voltage Clamp, in: Cardiac Gap Junctions, Karger Verlag, Basel, 1998
- Müller, A., M. Bachmann, H.R. Polder, S. Dhein, R. Berkels and W. Klaus (1998) Measurement of Gap Junction Conductance with Switched Single Electrode Voltage Clamp Amplifiers. No Effect of Series - and Input Resistance. Pflügers Archiv, [435](#): R238
- Müller, A., M. Lauen, R. Berkels, S. Dhein, H.R. Polder and W. Klaus (1999) Switched single electrode amplifiers allow precise measurement of gap junction conductance, American Journal of Physiology (Cell) Vol. 276, No.4 C980-C988, April 1999.

For more information please contact support@npielectronic.com (www.npielectronic.com).

SEC SYSTEMS WITH VCcCC MODE

General Description

The “Voltage Clamp controlled Current Clamp” (VCcCC) or “slow voltage clamp“ (SLOW VC) mode is used for performing accurate current clamp recordings in the presence of membrane potential oscillations. The npi single-electrode current- and voltage-clamp amplifiers (npi SEC 05/10 series) have been modified in a way that slow membrane potential oscillations are exactly controlled by the voltage-clamp module without affecting faster responses, e.g. postsynaptic potentials (PSPs) and action potentials (APs). The response speed of the voltage-clamp feed-back circuit has been decreased by incorporation of electronic circuits with large time constants (1 - 10000 s). In addition, through the current clamp input fast current stimuli (e.g. for conductance measurements) can be applied.

Operation

The VCcCC mode is controlled through two front panel elements (located in the VC part of the front panel): a toggle switch marked “on” / “off” and a rotary switch to set the time constants (1-10-100-1000, [optional 5000 and 10000] sec) for the low-pass filter. To start using the VCcCC mode, the amplifier must be tuned accurately in the fast VC mode (toggle switch “off”). The holding potential control must be set on the desired value, or a holding potential signal must be provided from an external device (e.g. computer). This holding potential will be the preset membrane potential for the VCcCC mode. Under these conditions, PSPs or other changes of the membrane potential will be voltage clamped.

If the toggle switch is set “on” the VCcCC mode is started. Depending on the preset time constant, fast changes of the membrane potential will not be voltage clamped any more. This is a condition that corresponds to an accurate current clamp. Fast changes of the membrane potential are monitored on the potential output, slow changes are compensated by the VCcCC circuit.

The time constant should be selected in a way that the signals under investigation are not altered by the VCcCC (please compare with current clamp recordings).

Important: The average membrane potential can be changed only through the VOLTAGE COMMAND INPUT. If changes are necessary, please select a short time constant (1 or 10 s).

CURRENT CLAMP INPUT

The current clamp input (CURRENT STIMULUS BNC connectors) is connected in the VCcCC mode in a way that fast current stimuli can be applied to the electrode. **The condition for such recordings is a ratio of >1:1000 between current pulse duration and VCcCC time constant.** Slow (long-lasting) current signals or DC (such as the HOLDING current) will be removed by the action of the VCcCC system. In the fast VC mode, the current clamp input is disconnected automatically. In this way, using the VCcCC mode, fast current stimuli can be used to monitor conductance changes.

LITERATURE

1. Peters, F., D. Czesnik, A. Gennerich & D. Schild, (2000) Low frequency voltage clamp: recording of voltage transients at constant average command voltage, J. Neurosci. Meth. Vol. 99, 129-135.
2. Sutor, B., S. Greiner-Fischer, B. Schlosser (2000) Pharmacologically isolated NMDA-EPSPs recorded at resting membrane potential of rodent neocortical neurons, Soc. Neurosci. Abstr., Vol. 26, Part 1, p 352.
3. Sutor, B. and H.R. Polder (2001) Slow Voltage-Clamp: A technique which allows switched current-clamp recordings of synaptic potentials at voltage-clamped holding potentials, Pflug. Arch. **441**:R221.

CALIBRATION of the x0.1 RANGE LOW VOLTAGE HEADSTAGE (SEC SYSTEM)

This headstage has an output current range of $\pm 15\text{nA}$ into maximum $100\text{ M}\Omega$, and the noise and bias current are reduced by a factor of 10 compared to the standard headstage. Therefore it is recommended for whole cell patch clamp recordings, although it can be used also with high resistance sharp microelectrodes.

All **current** related signals have to be divided by 10.

- CURRENT DISPLAY: XXX pA /no decimal point (100 = 100 pA)
- HOLDING CURRENT: XXX pA (100 = 100 pA)
- Input sensitivity: BNC labeled 1 nA/V has now 0.1 nA/V i.e. 1V = 100 pA
BNC labeled 0.1 nA/V has now 0.01 nA/V i.e. 1V = 10 pA)
- Output sensitivity: 1V/nA-100V/nA
- BRIDGE BALANCE: (XXX) x10 M Ω
- R_{EL} mode display: XXXX M Ω (i.e. 10 is 100 M Ω)

The **potential** input and output signals are **not** affected.

Calibration of SEC Amplifiers with x10 Headstage

(User's Manual page 10)

GENERAL: The current range of the x10 low voltage headstage is the following:

BR: 1.2 μ A into 10 M Ω (max. output voltage is 12 V), switched modes: 600 nA (duty cycle 50%), 300 nA (25%) and 150 nA (duty cycle 12.5%)

All current related inputs and outputs must be multiplied by a factor of ten.
This is valid for all four modes of operation (R_{EL}, BR, CC, VC)
Potential related signals are not affected.

CURRENT STIMULUS INPUT: 1 nA/V: corresponds 10 nA/V
0.1 nA/V: corresponds 1 nA/V
GATE: XX.X nA (max. 99.9 nA) (SEC10 only)
HOLDING: XX.X nA (max. 99.9 nA)

CURRENT OUTPUT SENSITIVITY: 0.1 V/nA corresponds 0.01 V/nA
older instruments (SEC-10L): 0.125 V/nA corresponds 0.0125 V/nA
0.2 V/nA corresponds 0.02 V/nA
0.5 V/nA corresponds 0.05 V/nA
1 V/nA corresponds 0.1 V/nA
2 V/nA corresponds 0.2 V/nA
5 V/nA corresponds 0.5 V/nA
10 V/nA corresponds 1 V/nA

CURRENT DISPLAY: shows correct current (XX.X nA), Maximum is 199.9 nA

BRIDGE BALANCE: XX.X M Ω (50 corresponds 5 M Ω), Maximum is 99.9 M Ω

ELELCTR. RESISTANCE DISPLAY: XXX M Ω (005 corresponds 5 M Ω), Maximum is 999 M Ω

Important: If high-resistance electrodes are used the capacity compensation must be set properly for exact determination of R_{EL}.

Example: HOLDING CURRENT: 100
corresponds to 10 nA, the DISPLAY will show 10.0 nA
INPUT at 1V/nA BNC: 1 V or INPUT at 0.1V/nA BNC: 10 V
corresponds to 10 nA, the DISPLAY will show 10.0 nA

voltage at CURRENT OUTPUT is then

CURRENT OUTPUT SENSITIVITY 0.1V/nA: 0.1 V
CURRENT OUTPUT SENSITIVITY 1 V/nA: 1 V
CURRENT OUTPUT SENSITIVITY 10 V/nA: 10 V

SEC-EXT Headstage for Extracellular Recordings with npi SEC Systems

The SEC-EXT headstage extends the range of operation of SEC amplifiers to the field of extracellular recordings. It has a differential high impedance input stage with capacity compensation for the non-inverting input (+ INPUT) and a gain of ten. This input stage is followed by a high pass filter with six corner frequencies (1; 3; 10; 30; 100; 300 Hz).

- DC output (POTENTIAL OUTPUT of the SEC): The direct output is connected to the "POTENTIAL" channel of the SEC system, i.e. the signal is passed through the OFFSET compensation stage, magnified by ten and filtered by the POTENTIAL FILTER. The overall gain for the DC output is 100 (x10 input stage, x10 SEC potential magnification).
- AC output (high pass output, CURRENT OUTPUT of the SEC): The output of the high pass filter stage is fed into the "CURRENT" channel of the SEC system, i.e. it is passed through the CURRENT OUTPUT SENSITIVITY stage where it is amplified (overall gains 10; 12.5; 20; 50; 100; 200; 500; 1000). The amplified signal is filtered by the CURRENT FILTER.

Important: The SEC system must be in BRIDGE (B) mode. All inputs must be turned off or disconnected. The BRIDGE balance control must be on 000 to avoid incoming disturbances.

The following systems and front panel elements are working:

CAP. COMPENSATION	Capacity compensation control for the non-inverting (+) input
POTENTIAL OUTPUT	DC output (x100)
OFFSET	Offset control for the DC output
POTENTIAL FILTER	Low pass Bessel filter for the DC output
POTENTIAL DISPLAY	Shows electrode potential x10 (100 are 10 mV)
CURRENT OUTPUT	AC (high pass) output (x10...x1000)
CUR. OUTPUT	Gain stage (10-1000) for the AC output
SENSITIVITY	
CURRENT FILTER	Low pass Bessel filter for the AC output
OSCILLATION	as described in the SEC manual
SHUTOFF	
PENETRATION	"BUZZ" as described in the SEC manual (+Imax/-Imax do not work)

Important: This headstage is sensitive to static discharges. It is equipped with very sensitive FET amplifiers, which can be damaged with electrostatic charge and must therefore be handled with care. Damage can be avoided by touching a grounded metal surface when changing or adjusting the electrodes. If a headstage is not used the input should always be connected to ground (either using an appropriate connector or with aluminum foil wrapped around the headstage). **Always turn power off when connecting or disconnecting headstages from the 19" cabinet.**

For more information please contact support@npielectronic.com (www.npielectronic.com).

SEC SYSTEMS WITH LINEAR (x1 AND x10) MODE

General Description

The linear mode of the SEC amplifier is an “unswitched” operation mode of the SEC, working in voltage clamp (VC) and current clamp (CC). In contrast to standard patch clamp amplifiers the electrode voltage is nevertheless measured, also in VC. However, due to current flow during voltage measurement, this measurement is distorted by the series resistance. This is the reason why the linear mode should be used only for recordings where only little current flows.

In the linear mode the background noise of the amplifier is substantially reduced. Therefore, the linear mode is predestined for low-noise recordings in VC and CC mode.

The linear mode allows also **loose-patch** or **macro-patch** recordings, and can be used to approach the cell and form a gigaseal in VC mode.

The LIN x10 mode can be used for iontophoresis or electroporation, i.e. juxtacellular, non-invasive filling of cells with or single cell transfection with DNA. The stimulus amplitude range in CC or BRIDGE mode is also enhanced to max. ± 120 nA.

Operation

The linear mode is set through the Linear Mode switch at the front panel. When the switch is set to the middle position, the amplifier is in “switched” (VC or CC) or in BRIDGE mode (CC). Setting the switch to x1 or x10 lets the amplifier work in linear mode either without or with x10 amplification.

Linear Mode - x1/x10 switch

- x1: The amplifier operates in linear, unswitched mode (see below), current and/or voltage are not enhanced. LIN LED lights green.
- x10: The amplifier operates in linear electroporation mode. Command voltage in VC or current stimulus in CC or BRIDGE mode are multiplied by the factor of ten. This allows to apply stimuli of max. ± 120 nA. In this operation mode the LIN LED lights red and the voltage output at POTENTIAL OUTPUT x10mV BNC connector is set to **x1mV**.
- middle: In the middle position of this switch the amplifier works in switched or BRIDGE mode. The LIN LED does not light.

Important: In LIN x10, the voltage output (POTENTIAL OUTPUT x10 mV BNC connector) is set to **x1 mV**, i.e. 1 V is 1 V (and not 100 mV as in LIN mode x1).

Important: The linear mode must be used with low resistance patch pipettes only! Ringing can be avoided by setting the GAIN in VC mode not higher than 1 and by setting the capacity compensation of the electrode to very low values (best close to zero).

Note: Be always aware, that the linear mode introduces a series resistance error that is dependent on the magnitude of series resistance and current that flows during measurement.

Important: The LIN mode x1 or x10 **must not be used** if two SEC amplifiers work in synchronized (Master/Slave) configuration.

Important: BRIDGE balance and Capacity Compensation work in LIN mode and can be used to minimize artifacts during electroporation.

SEC-10 SYSTEMS WITH DHC MODE

General Description

The “Dynamic Hybrid Clamp” (DHC) mode is used for investigations of ionic conductances in voltage clamp (VC) mode following action potentials in current clamp (CC) mode. In CC mode an action potential is detected by a spike detector and triggers a timing unit. This timing unit generates a TTL signal for triggering the SEC (being in CC mode). The SEC switches from CC mode to VC mode with the actual membrane potential as holding potential.

Operation

The DHC mode is set through the an additional switch labeled DHC at the front panel.

Important: The SEC must be in CC mode in order to use the DHC feature.

When the switch is set to DHC (amplifier must be in CC mode) the membrane potential is fed into a sample-and-hold electronic. If a TTL pulse (+5 V) is applied to the BNC connector under the DHC switch, the SEC is switched to VC mode. The COMMAND INPUT for voltage clamp is disabled and the command potential is provided by the sample-and-hold electronic, e.g. the command potential represents the last membrane potential before switching to VC mode.

In practice, the investigator needs additionally a spike detector and a timing unit. The spike detector detects an action potential and triggers – with a possible delay set by the timing unit – the transition from CC mode to VC mode.

Literature

Dietrich, D., Clusmann, H. & Kral, T. (2002). Improved hybrid clamp: resolution of tail currents following single action potentials. *J.Neurosci Meth.* **116**, 55-63.